

# 1 GENERAL

## 1.1 Performance Data

### 1. Main dimension (Table 1-1)

Table 1-1

Item	Data		
	HFJ6371、HFJ6371B、 HFJ6371C、HFJ6371E、 HFJ1012、HFJ1012B、 HFJ1012C 、HFJ1012E	HFJ6376、HFJ6376E HFJ1016 、HFJ1016E	HFJ6350C、HFJ6351C、 HFJ6351CA
Length(mm)	3721	3745	3562
Width(mm)	1480		1480
Height(mm)	1918		1918
Wheel base(mm)	1960		
Tread (mm)	Front	1235 (1215)	
	Rear	1220 (1200)	
Front overhang(mm)	942	966	783
Rear overhang(mm)	819		819

### 2. Mass data (Table 1-2)

Table 1-2

Item	Data						
	HFJ6350C	HFJ6351C、 HFJ6351CA	HFJ6371、 HFJ6371E HFJ6376、 HFJ6376E	HFJ6371B 、HFJ6371E HFJ6376、 HFJ6376E	HFJ6371C	HFJ1012 HFJ1016、 HFJ1016E、 HFJ1012E	HFJ1012E、 HFJ1012B HFJ1016 HFJ1012C
Curb weight	940kg	970kg	980kg	960kg		940kg	
Max. total weight	1460kg	1460kg	1530kg				
The rated load (passenger numbers)	660kg/800kg 6~8	670kg/790kg 6~8	5~8 (5~7)		5~8	2+440kg or 5+245kg	2+460kg or 5+265kg
Empty axle-load (front/rear)	480kg/460kg	495kg/475kg	---			---	

### 3. Performance data (Table 1-3)

Table 1-3

Item	Data
------	------

	HFJ6371、HFJ6376 HFJ1012、HFJ1016、 HFJ6351C	HFJ6371B、HFJ6376 HFJ1012B、HFJ1016	HFJ6371C HFJ1012C	HFJ6350C	HFJ6351CA
Engine mode	DA465Q-1A	DA465Q	DA462-1A	DA462-1A	DA465Q
Max. speed	≥105km/h	≥100km/h	≥95km/h	≥100km/h	≥110km/h
Max. slope of climb	≥20%				
Fuel consumption of 100km at constant speed	≤5.8L(40km/h)				≤5.5L(40km/h)
Tank capacity	36L				
Min. turning diameter	9.0m				
Min. ground clearance	≥150mm		≥165mm		≥150mm

#### 4. Engine data( Table 1-4)

Table 1-4

Item	Data		
	HFJ6371、HFJ6376 HFJ1012、HFJ1016 、HFJ6371E、HFJ6376E HFJ1012E、HFJ1016E、 HFJ6351C	HFJ6371B、HFJ6376 HFJ1012B、HFJ1016、HFJ6371E、 HFJ6376E HFJ1012E、HFJ1016E、 HFJ6351CA	HFJ6371C HFJ1012C、HFJ6350C
Mode	DA465Q-1A	DA465Q	DA462-1A
Type	Four cylinder, four stroke, tandem, water cool, overhead camshaft, electronic fuel injection (EFI)		
Cylinder diameter	65.5mm	65.5mm	62mm
Stroke	78mm	72mm	72mm
Displacement	1051ml	970ml	870ml
Rated power	38.5kW/5200r/min	35.5kW/5000r/min	27kW/5200r/min
Rated torque	83N.m/3000~3500r/min	74N.m/3000~3500r/min	60N.m/3000~3500r/min
Compression ratio	9.0:1	8.8:1	8.7:1
Ignition advance angle	6° ~7°		
Min. fuel consumption rate	275g/(kW · h)	275g/(kW · h)	300g/(kW · h)

#### 5. Transmission system (Table 1-5)

Table 1-5

Item	4MT	5MT	
Clutch type	Single disc, dry and with diaphragm spring	Single disc, dry and with diaphragm spring	
Gear box type	Synchromesh type	Synchromesh type	
Main gear reduction ratio	5.125	5.125/4.444	5.125/4.444
Gear ratio			
1 <sup>st</sup> gear	3.505	3.652	3.505
2 <sup>nd</sup> gear	2.043	1.948	2.043
3 <sup>rd</sup> gear	1.383	1.424	1.383
4 <sup>th</sup> gear	1.000	1.000	1.000
5 <sup>th</sup> gear		0.795	0.806
Reverse gear	3.536	3.466	3.536

## 6. Wheel and suspension (Table 1-6)

Table 1-6

Item	HFJ6350C、HFJ6351C、HFJ6371series		HFJ6376 系列
Tire type	165/70 R 13	155R12C	165/70 R 13
Air pressure empty load (front/rear)	210kPa/250kPa	200kPa/220kPa	180kPa/220 kPa
Full load (front/rear)	250kPa/250kPa	300kPa/350 kPa	220kPa/250 kPa
Front suspension type	MC, pherson type independent suspension		
Rear suspension type	Parallel leaf spring type rigid axle suspension		

## 7. Steering system (Table 1-7)

Table 1-7

Item	HFJ6350C、HFJ6351C、HFJ6376series、HFJ6371series
Steering gear type	Rack and pinion type
Kingpin inclination	12° ±30'
Caster	6° ±30'
Camber	0° ±30'
Toe-in	0~5mm

## 8. Brakes (Table 1-8)

Table 1-8

Item	HFJ6350C	HFJ6351Cseries、HFJ6376series、HFJ6371series
Brake type	Dual hydraulic lines braking	Dual hydraulic lines braking (with vacuum power)
Front wheel brake	Balanced double leading shoes and drum type brake	Full sliding caliper disc brake/ Balanced double leading shoes and drum type brake
Rear wheel brake	Unbalanced leading/trailing shoes and drum type brake	Unbalanced leading/trailing shoes and drum type brake
Parking brake	Mechanical cable type (acting on rear wheels)	Mechanical cable type (acting on rear wheels)

## 2 INSPECTION DATA AND MAINTENANCE PERIOD

### 2.1 TORQUE

The tightening performance of connecting bolt and nut is performed by screw thread. Each fastener should be tightened to the torque specified in each section with moment wrench during maintenance.

Table 2-1

System	Tighten position	Specified torque(N · m)	
		<i>N · m</i>	<i>kgf · m</i>
Engine	Cylinder head setscrew	55~60	5.5~6.0
	Spark plug	19.6~29.4	2.0~3.0
	Intake and exhaust manifold nut	17.7~22.6	1.8~2.3
	Driven synchronous gear screw	49.0~58.8	5~6
	Valve adjust nut	14.7~19.6	1.5~2
	Initiative synchronous gear screw	49.0~58.8	5~6
	Connecting rod bearing cap nut	27.5~31.4	2.8~3.2
	Crankshaft main bearing cap bolt	42.2~47.1	4.3~4.8
	Flywheel screw	39.2~44.1	4.0~4.5
	Oil plate screw	3.92~4.90	0.4~0.5
	Oil drain plug	19.6~24.6	2.0~2.5
	Rocker arm cap screw	3.92~4.90	0.4~0.5
	Synchronous chain cover setscrew	2.94~3.92	0.3~0.4
	Setscrew of oil pump	7.85~9.81	0.8~1.0
	Oil pressure sensor	11.8~14.7	1.2~1.5
	Oil filter stand	9.81~14.7	1.0~1.5
	Setscrew of oil filter nib	19.6~24.5	2.0~2.5
	Rear engine bracket-Body fastening bolt	10.8~13.7	1.1~1.4
	Oil pump safety valve spring seat	14.7~19.6	1.5~2.0
	Left and right engine hangers fastening bolt	17.7~22.6	1.8~2.3
	Bracket mounting bolt	24.5~29.4	2.5~3.0
	Tension pulley bracket bolt and nut	14.7~22.6	1.5~2.3
	Ignition shock sensor screw	15~25	1.5~2.6
O <sub>2</sub> sensor	40~60	4~6	
Coolant temperature sensor	Max. 20	Max. 2	

<b>Transmission</b>	Transmission case screw	14.7~19.6	1.5~2.0
	Drain plug and oil filler	29.4~49.0	3.0~5.0
	Extention case bolt	14.7~19.6	1.5~2.0
	Rear bracket mounting bolt	14.7~19.6	1.5~2.0
	Gear shift shaft case screw (M8)	8.83~11.8	0.9~1.2
	Gear shift shaft case screw (M6)	5.88~9.81	0.6~1.0
	Gear shift crossing shaft lock screw	14.7~19.6	1.5~2.0
	Connecting bolt of transmission and cylinder	19.6~24.5	2.0~2.5
Cluth	Cluth pressure plate bolt	17.7~27.5	1.8~2.8

## 2.2 INSPECTION DATAS

**The content of engine refers to 《HFJ6351B service manual》。**

## 2.3 MAINTENANCE SCHEDULE

Interval: This interval should be judged by odometer reading or months, whichever comes first.	km× 1000	2.5	10	20	30	40	50	60	70	80
	months		2	6	12	18	24	30	36	42

**ENGINE**

1	Water pump(fan) drive belt(tension, damage)	A	—	I	—	R	—	I	—	R
2	synchronizing toothed belt (wear and damage)	I	—	I	—	I	—	I	—	I
3	IN and EH valve clearance	A	—	A	—	A	—	A	—	A
4	Engine bolts (All cylinder head and manifold fixings)	T	—	T	—	T	—	T	—	T
5	Engine oil filter	R	R	R	R	R	R	R	R	R
6	Engine oil	Replace every 5000km. More frequent replacement if under dusty driving conditions								
7	Fuel hoses and connections ( hoses aging , connections crack, damage or loosening)	I	I	I	I	I	I	I	I	I
8	Cooling system hoses and connections (leakage, damage)	—	—	I	—	—	I	—	—	I
9	High tension cords (aging and damage)	—	—	I	—	—	I	—	—	I
10	Crankcase hose and nib	—	—	I	—	—	I	—	—	I
11	Spark plugs	—	R	R	R	R	R	R	R	R
12	Ignition timing	I	A	A	A	A	A	A	A	A
13	Ignition shock sensor tightening torque	A	A	A	A	A	A	A	A	A
14	Air filter	Clean every 1000km on asphalt road and clean every 2500km on dusty road								
●		Dust road	Check referring to hard driving							

15	Acceleration cable and throttle valve spindle	—	I. L	I.L	I.L	I.L	I.L	I.L	I.L	I.L
16	Fuel filter	—	—	—	—	R	—	—	—	R
17	PCV valve	—	—	I	—	I	—	I	—	I
18	Clutch gap									
19	Gear oil of transmission (check leakage at normal level)	R	I	I	I	R	I	I	I	R
20	Damage and fastness of harness	I	I	I	I	I	I	I	I	I
21	Coolant	—	—	—	—	R	—	—	—	R
22	Charcoal canister	Replace every 50000km. More frequent check if under dusty driving condition. Replace in time if clogging or liquid fuel found.								
23	Catalytic converter	—	—	—	—	—	—	—	—	I
24	Wiring harness connections and headlights	—	—	I	—	I	—	I	—	I
25	Clutch pedal play	I	I	I	I	I	I	I	I	I
26	Brake fluid(lever、leakage)	I	I	I	I	R	I	I	I	I
27	Brake pedal play	I	I	I	I	I	I	I	I	I
28	Parking brake lever and cable (stroke and damage)	I	I	I	I	I	I	I	I	I
29	Brake discs and pads (wear, damage) Brake drums and shoes (wear, damage)	—	I	I	I	I	I	I	I	I
30	Brake hoses and pipes (leakage, damage, clamp)	—	I	I	I	I	I	I	I	I
31	Tires (abnormal wear and pressure)	—	I	I	I	I	I	I	I	I
32	Wheel, wheel nut (damage、torque)	I	I	I	I	I	I	I	I	I
33	Shock absorber(oil leakage 、 damage)	I	I	I	I	I	I	I	I	I
34	Propeller shaft (damage)	—	—	I	—	I	—	I	—	I
35	Transmission and Differential oil (leakage, lever)	R	I	I	I	R	I	I	I	R
36	Main bolt and nut (tightness)	T	—	T	—	T	—	T	—	T

37	Steering (tightness, damage, rattle, breakage)	I	I	I	I	I	I	I	I	I
38	Middle arm bush assy(lubrication and tightness)									
39	Test drive	Test drive on completion of each service								

**Notice :**

“A”—Inspection and connect ;“R”—Replace or repair;“T” —Tighten to the specified torque; “L” —Lubricate “I” —Inspection and correct or replace if necessary;

## 3 TROUBLE SHOOTING

## 3.1 ENGINE

TABLE 3-1

Condition	Possible cause	Correction
<b>Hard starting</b>	a、 Starter will not run 1. Loose battery terminal connection 2 Brack-circuited in cord connection 3 Defective of starter	Clean and retighten Check or repair Repair or replace
	b、 No sparking 1 Improper ignition timing 2 Poor grounded 3 Cracked rotor or cap in distributor 4 Defective ignition coil 5 Improper clearance or burnt in spark 6 Brack-circuited or short-circuited in cord connection 7 Connector loose or damaged 8 Damage of main breaker contact 9 Defective ECU	Adjust Repair Replace Replace Adjust or replace Check or repair Adjust or replace Replace Repair or replace
	c、 Malfunction of the fuel system 1. Electronic fuel pump feed fuel pressure Lack 2. Fuel injectors damaged or clogged 3 Fuel hose fold and fuel filter clogged 4 Vacuum hose or fuel pressure adjuster broken off or damaged 5 Connector loose or damaged 6 Damage of main breaker contact or oil pump breaker contact 7 short-circuited or open-circuited 8 Defective ECU	Repair or replace Replace or Clean Replace Installation or replace Replace or adjust Replace Check and repair Replace
	d、 Inadequate compression 1 Damaged cylinder gasket 2 Improper valve clearance 3 Worn pistons, rings or cylinder	replace Adjust, repair or replace repair or replace
<b>High idling</b>	1. ECU doesn' t self-study after break 2. Throttle can' t restore completely 3. Intake system leakage 4. Idle adjuster (stepper motor) damaged	Flameout, then self-study check and adjust check and repair replace

Not enough power	1Accelerator control and throttle cable improperly adjusted 2 Cylinder compression pressure reduce 3Improper ignition timin 4Fuel pressure adjuster damaged and make fuel feeding reduce 5Insufficient intake 6Clogged exhaust 7Defective spark plug or improper spark clearance 8 Firing a gun when engine racing 9 Fuel injectors clogged or damaged 10 Clogged fuel filter 11 Damaged throttle position sensor 12 Defective fuel pump or insufficient pressure	Adjust 1 check valve、 spark plug、 cylinder gasket leakage; 2 Valve rubbing Adjust Adjust or replace Check inlet system Check exhaust system or clear away carbon deposit Adjust or replace Check high voltage wire Clean or replace Replace Replace Repair or replace
Enging noise	1 Worn bearing, crank and arm. 2 Worn crankshaft,connecting-rod bearing and piston 3 Worn piston ring 4 Improper valve clearance 5 Valve clearance too large	Replace <b>Replace or repair</b> Replace Adjust Adjust
Overheating	1 Improper ignition timing 2 Inexactitude clearance of spark plug or accumulated carbon. 3 Loose of air intake manifold or jam of exhaust manifold. 4 .Loose of water wheel belt 5 Lack of coolant or jam of hose. 6 Inexactitude clearance or damage of water pump 7 Lack of oil 8 Damage of oil pump or jam of lubricating way. 9 Damage of cyclinder gasket 10 Slipping cluth 11 Jam of radiator	Adjust Clean or adjust Retighten or clean Adjust Refill or clean Repair or replace Refill Clean or replace Replace Repair or replace Clean or replace
Excessive engine oil consumption	1 Defective valve guide bushes oil seals 2 Sticky piston ring 3 Worn piston ring groove and ring 4 Improper location of piston ring gap 5 Badly worn valves or valve guide bushes 6 Exhaust of oil through breeze hole by high pressure which caused by overheat.	Replace Replace Adjust Replace Replace Check relative position
Hard shifting	1 Wron synchronizer hub 2 Wron synchronizer gear 3 Broken locating balls 4 Distorted or unevenly worn shift fork shaft	Replace Replace Replace Repair or replace

Noisy clutch	<ol style="list-style-type: none"> <li>1. Worn or broken release bearing</li> <li>2. Input shaft front bearing worn down</li> <li>3 Excessive rattle of clutch disc hug</li> <li>4 Cracked clutch disc</li> <li>5 Pressure plate and diaphragm spring rattling</li> <li>6 Clutch facings soaked with oil</li> <li>7 Weakened torsion spring</li> </ol>	<p>Replace</p> <p>Replace</p> <p>Repair</p> <p>Replace</p> <p>Repair or replace</p> <p>Clean or replace</p> <p>Replace</p>
<b>Bright of trouble pilot lamp in panel</b>	<ol style="list-style-type: none"> <li>1 Trouble of EFI system</li> <li>2 Trouble of wire</li> </ol>	<p>Diagnose with Hi-Scan</p> <p>Check ( if connect firmly 、 break-circuit or short-circuit)</p>
Poor emission	<ol style="list-style-type: none"> <li>1 Damage of TWC and O<sub>2</sub> sensor, which caused by use of lead fuel.</li> <li>2 Damage of TWC and O<sub>2</sub> sensor, which caused by misfire of ignition system.</li> <li>3 Leakage of exhaust system, ECU can' t get the right signal of O<sub>2</sub> sensor, causing air/fuel ratio rich</li> </ol>	<p>Replace</p> <p>Replace</p> <p>Repair</p>

## 4 ENGINE

### 4.1 General

**The engine is** in-line 4-cylinders, water-cooled, 4-stroke cycle MPI gasoline unit with valve mechanism arranged for “V”-type valve configuration and overhead camshaft, which is installed in cylinder head and driven by crankshaft with timing chain. With compare to general model, no valve lifter is available in the model, so that valves is driven in more directive method and open or close more promptly (See Fig.4-1).

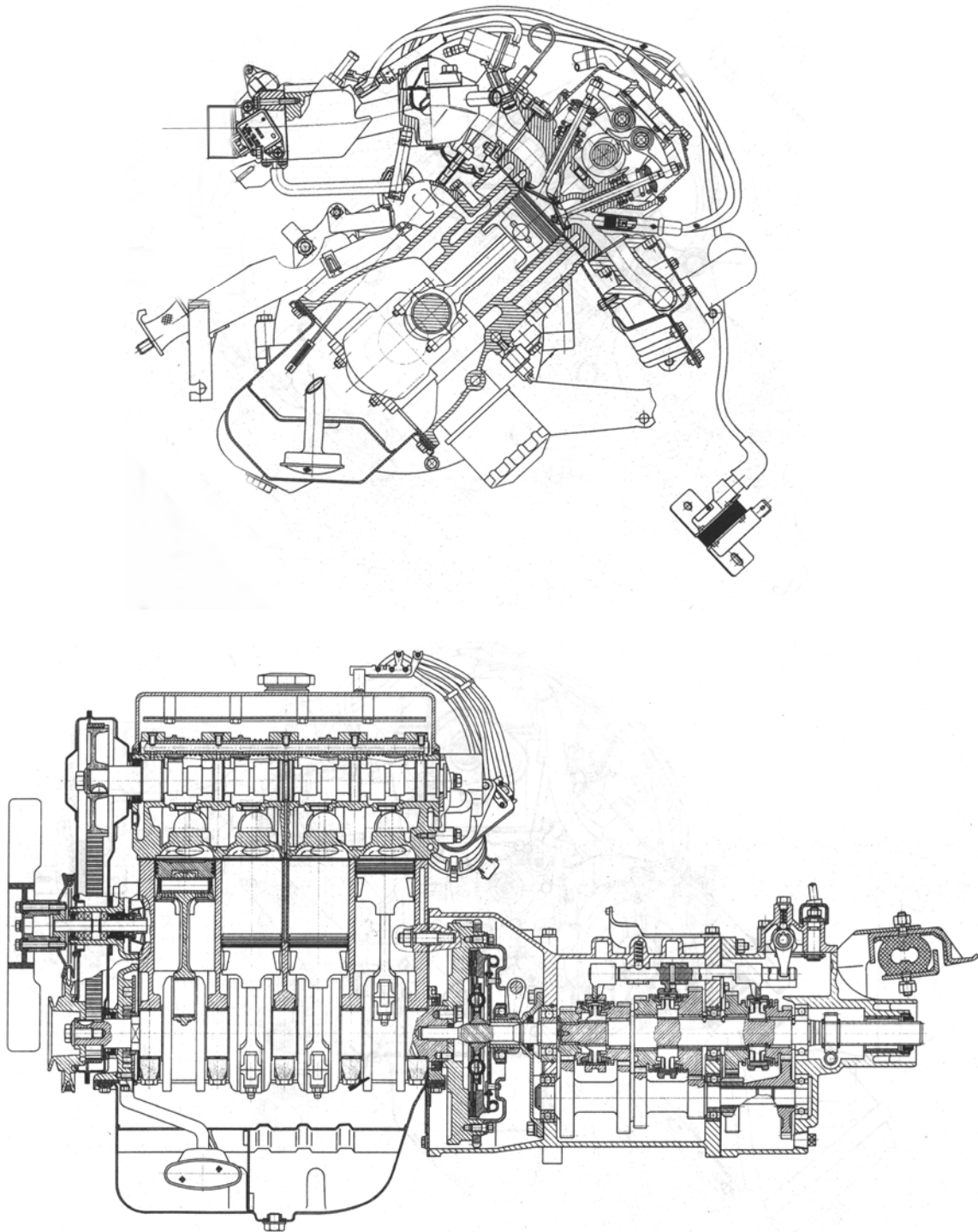

Fig.4-1

The engine adopts BOSCH M1.5.4 EMS or DELPHI EFI system. Comparing with carburetor engine, a great improvement has made in power, economic and low temperature starting performances.

The engine that has functions of sequential ignition, sequential injection, knock closed-loop control, idle closed-loop control, canister control, A/C control etc, with distributor, is a closed-loop control engine manage system. Sensors available for the system include TPS(throttle position sensor), MAT/MAP(manifold air temperature & pressure sensor), knock sensor, coolant temperature sensor, oxygen sensor, rotation speed sensor ( in distributor, also called Hall sensor). The actuators include fuel pump (inside fuel tank), injectors, ignition coils, idle adjustor(also as stepper motor), purge valve.

#### • ENGINE CHARACTERISTICS

- Valves in the head is arrayed in V type with inlet pipe and exhaust pipe in configuration of orthogonal flowing pattern, so that efficiency of charge and exhaust is high.

- Combustion chamber shape is multi-sphere, with low burning consumption and high power performance.

- The camshaft and the rocker arm shaft are installed in the head for more solid construction, which reduce noise from inlet system and quantity of parts in induction system. These make engine more compact.

- The timing chain driving camshaft has characteristics of light weight and small operating noise.

- The engine block uses material of high quality iron-casting and has a construction of gantry for high rigidity.

- The crankshaft are constructed of one-piece forged alloy steel , which supports with five bearings and have an advantage of low vibration.

- The exhaust manifold and pipe adopt double pipe type, for no interference with each other. One pipe is connected to 1st and 4th cylinders, the other to 2nd and 3rd cylinders.

- Electronic fuel injection system has a central unite of ECU(electronic control unit), which control accurately quantity of injecting fuel, ignition advance, so that engine works well under varies operation conditions.

- Use three-way catalytic converter to reduce CO, HC and NOx, emissions in exhaust, in order to make the vehicle become GREEN MOTOR.

- Crankcase emission controls

Leakage pipeline is located in the block. The leakage flows to the head through crankcase, and fuel is separated from the air with separation plate in the head before it is taken out.

## 4.2 PRINCIPLE AND CONSTRUCTION OF EMS

### 1. Parts

As general electronic control system, there are three portions that construct electronic control fuel injection system: sensors, control unit, actuators.

#### (1) Sensors

Sensor is a device that responds to a physical stimulus (heat, light, sound, pressure, motion, flow, and so on), and produces a corresponding electrical signal, which can be used by ECU. General sensors in EFI include load sensor which responds to air volume every cycle directly or indirectly, rotation speed sensor which responds to engine speed, crankshaft position sensor which responds 1st cylinder TDC; TPS, coolant temperature sensor, air charge temperature, barometric pressure sensor, oxygen sensor which responds to oxygen volume in exhaust and is used by closed control, manifold inlet pressure sensor.

#### (2) Electronic Control Unit (ECU)

The device is applied to receive and handle signals from sensors, instruct actuators to control engine.

#### (3) Actuators

Actuators are applied to do instructions of ECU and control fuel quantity. Main parts include power fuel pump and magnetic injectors.

#### • Variables

Control variables are applied to decide instructions for actuators by ECM, such as gasoline load, engine speed, coolant temperature, air temperature, air pressure etc. features. In general, one sensor informs one piece of information.

Two more important variables in various variables of engine (known as main control variables) are engine speed and engine load.

For engine, the load can be informed with air volume each cycle. When knowing engine speed, it is easy to know air volume every cycle according air volume every time unit. So generally use air charge as load.

ECU decides basic injecting quantity and basic ignition BTDC by main control variables value and modify those values by other sub information such as coolant temperature, air temperature, so that accept last values about injecting quantity and ignition advance.

#### • INFORMATION FLOW OF EMS

Information flow of EMS is shown in Fig.4-2.

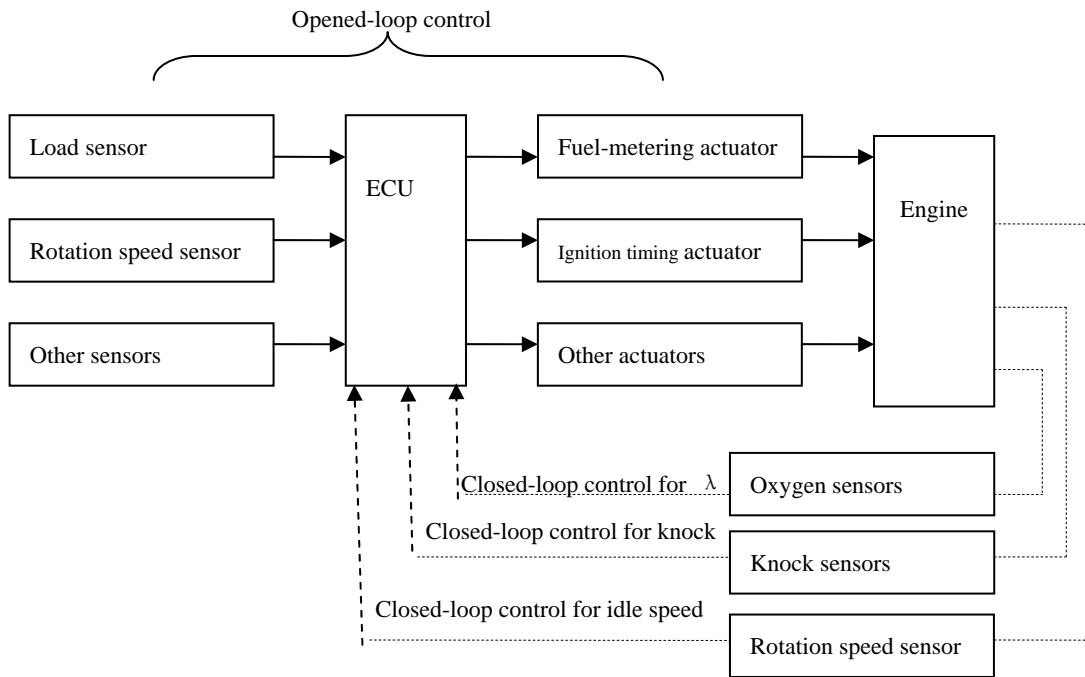

Fig. 4-2

ECU receives various information about engine responded by sensors to calculate and product instructions to actuators to make engine operate in perfect condition, which the power fuel pump and the injectors carry out fuel-metering injection, and the ignition coil and the distributor carry out ignition control.

Results of control is unknown by the way of the foregoing statement. Sometimes it is necessary to keep a feature in a range, for example, to make air/fuel close to theory air/fuel ratio 14.7 for satisfying emissions requirements or keep idle speed near 850r/minn or prevent knock on high-load condition. Closed-loop control is a way that forms close circuit in EMS. On the other hand, opened-loop control system is a control system that doesn' t form close circuit. The portion of short-line is closed-loop control, the portion of solid-line is opened-loop control (Fig 4-2).

It is necessary to indicate that it is impossible for electronic control system to change engine operating condition. Only external conditions, like man or engine operating environment, can change engine operating condition by changing engine main control variables. For example, engine operating condition is changed because throttle open degree is changed, which air volume charged is changed, or a vehicle is driven on upright from flat ground, engine speed will reduces though other conditions aren' t changed.

## 2. Principle

Electronic fuel injection system is a system that the central part is engine electronic control unit.

Sensors installed on positions of engine respond to various operating

features and inform ECU.

According to this information, engine-ECU controls injecting quantity, ignition advance accurately, based on preparing control program to make engine operate perfectly in various conditions.

When ignition switch ON, ECU or ECM is powered. As soon as the first crank rotation signal is checked, the fuel pump is powered and fuel pressure is built up with the pump. The fuel flows to fuel distribution pipe on engine through fuel filter and then the injectors installed on inlet manifold near intake ports, which inject fuel into cylinders. The fuel pressure, which is controlled with the pressure regulator on end of fuel rail, is 300kPa for both systems. Because pressure difference is constant with pressure regulator and section area of injector is constant too, so ECU can control injecting quantity every cycle by means of controlling the injector on-time. When injector opens, fuel is injected into manifold which mixes with air and is inducted into cylinder on inlet stroke to fire.

Driver can control throttle open degree with acceleration pedal to control air volume. ECU receives information such as air temperature, coolant temperature, air pressure, engine speed etc. and calculates out air volume and basic injecting period.

In a real run, after the basic injecting period is calculated, a modified value is prepared by information of feedback signal of oxygen sensor on exhaust system, instant load, battery voltage etc. ECU corrects the injecting quantity to actual injecting quantity. ECU decides accurate injecting phase by preprogramming data, engine speed or crank position signals.

BOSCH M1.5.4 EMS adopts a pattern of sequential ignition with distributor.

DELPHI adopts a pattern of directive ignition without distributor. Drive circuit in ECU opens or closes ignition coil primary circuit, and supplies ignition signals to 1-4 cylinders and 2-3 cylinders.

Both systems have self-diagnosis function. The service light in meter is lighted when troubles occur.

Vehicle will operate in hiccup pattern while parts in the system have trouble. There is a connector for tester.

BOSCH M1.5.4 is shown in Fig. 4-3 a).

DELPHI system is shown in Fig 4-3 b).



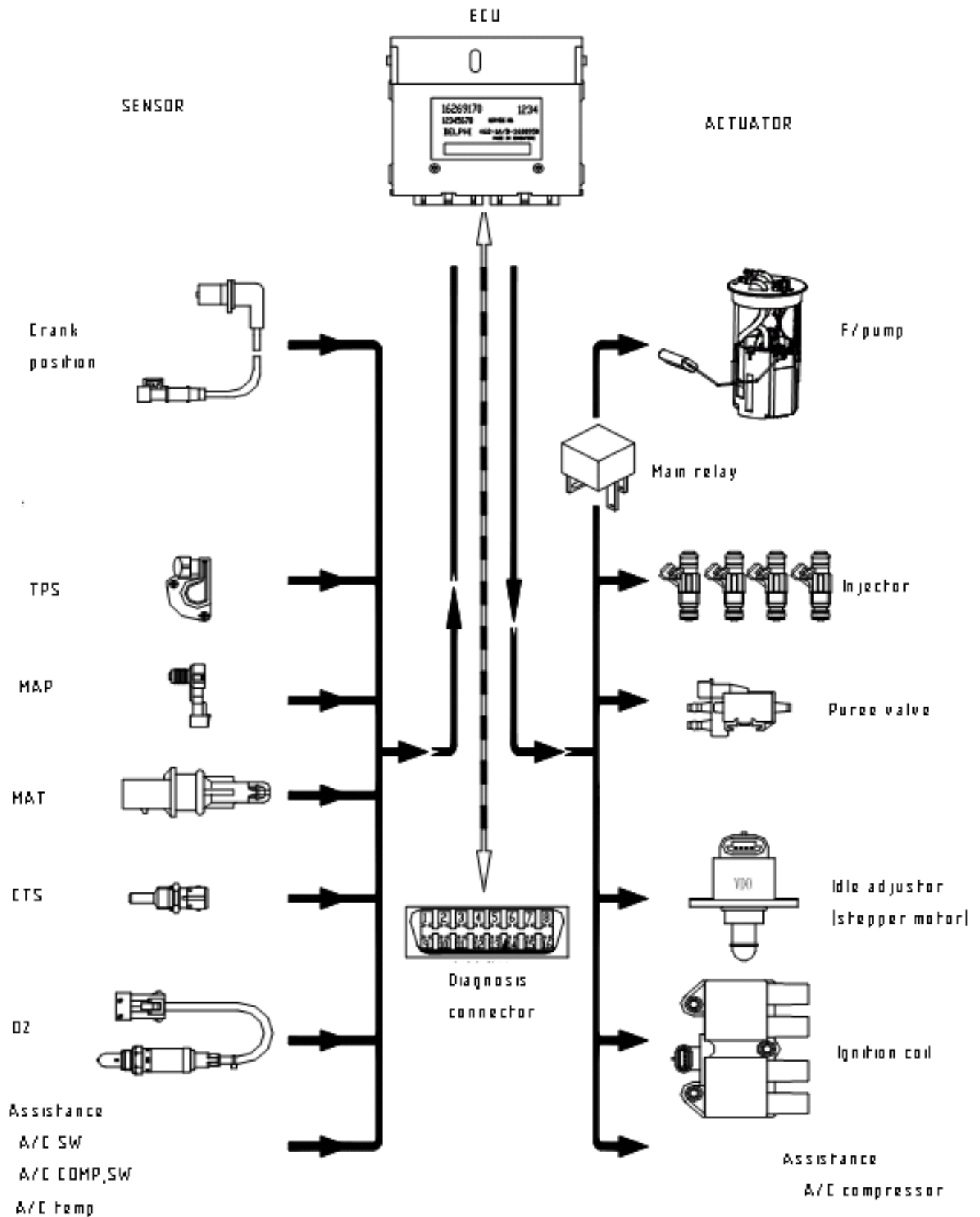

Fig 4-3b)

• SENSORS

1) Throttle position sensor

A sensor which is installed on throttle assembly coaxially (throttle assembly install

on the front end of intake pipe), provide load, load range and acceleration information. Throttle position sensor monitors open degree of the throttle. The sensor is resistance type, which is powered with 5V by ECU and products voltage signal to ECU. The circuit diagram sees Fig. 4-4a).

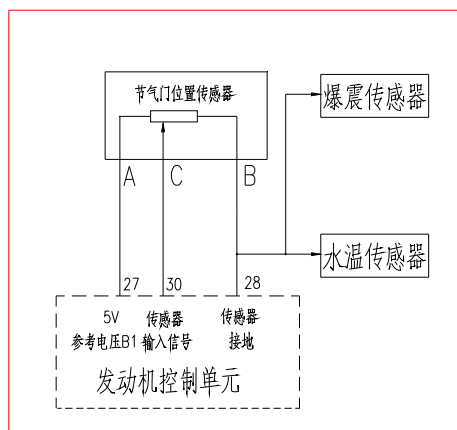

节气门位置传感器—Throttle position sensor(TPS)

爆震传感器- Knock sensor

水温传感器-Coolant temperature sensor

参考电压-Ref. Voltage

传感器输入信号-Sensor input signal

传感器接地-Sensor earth

发动机控制单元-Engine-ECU



b) (BOSCH)



c) (DELPHI)

FIG. 4-4

Item	BOSCH (Fig. 4-4b)
Resistance (1-3)	1.95~2.10K $\Omega$
Resistance (2-3)	1.10~2.80K $\Omega$
Full close -full open	

Item	BOSCH (Fig. 4-4a)	DELPHI (Fig. 4-4c)
Full close	0.1V~0.9V	0~0.25V
Full open	3.0V~4.8V	0~5V

2) Intake temperature/pressure sensor (Fig4-5a) ,Fig. 4-5b))

A sensor is installed on the intake manifold stable pressure chamber to offer engine load and temperature information, which is used to decided injecting quantity and ignition timing.

For BOSCH M1.5.4 , the voltage of 5V, which is supplied by ECU powers the sensor. Voltage between terminal 4 and ground is in a range of 3.8 – 4.2V. Voltage responded to pressure is 0.8 - 1.3V while idling,1.521 - 1.683V for 40kpa and 4.859~5.043V for 102kpa。 Using ohmmeter to measure resistance between terminals 1,2, the value should be 2.2~2.7K  $\Omega$  for 20°C and 1.1~1.4K  $\Omega$  for 30°C. If faulty, replace the sensor, see fig.4-5) .

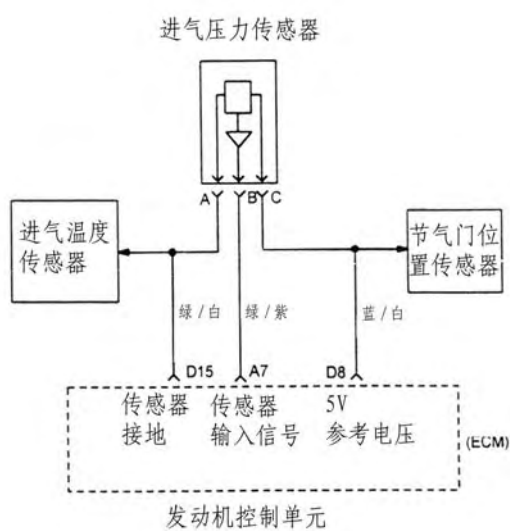

Fig.4-5a)

• Intake pressure sensor for DELPHI system

Be installed on the intake manifold stable pressure chamber to provide engine load information. ECU provide 5V voltage to the sensor, the sensor responds to manifold pressure of different lode and rotate speed which is changed to voltage single and transmitted to ECU,FIG. 4-5b), FIG.4-5c)。

Operation voltage: 0.122~0.382V/15kPa  
 1.521~1.683V/40kPa  
 4.438~4.600V/94kPa  
 4.859~5.043V/102kPa



进气压力传感器: Intake pressure sensor  
 进气温度传感器: Intake temperature sensor  
 节气门位置传感器: Throttle position sensor(TPS)  
 传感器接地: Sensor earth  
 传感器输入信号: Sensor input signal

参考电压: Ref. Voltage

发动机控制单元: Engine-ECU

蓝/白-LW  
 绿/白-GW  
 绿/紫-GV

FIG. 4-5b)



FIG. 4-5c)

- Intake temperature sensor for DELPHI system

Installing in air filter and provide air temperature information which is used to confirm amount of injection and ignition timing. The end voltage is direct ratio change with resistance. Its resistance decreases with temperature increasing.

Intake temperature sensor responds to temperature and product voltage signal which is transmitted to ECU or ECM to control injecting quantity and ignition timing. FIG. 4-5d), FIG. 4-5e), MT20 see 4-5f).

Resistance value:

$178 \pm 2.3 \Omega / 100^\circ\text{C}$     $333.8 \pm 2 \Omega / 80^\circ\text{C}$     $3511 \pm 2.6 \Omega / 20^\circ\text{C}$

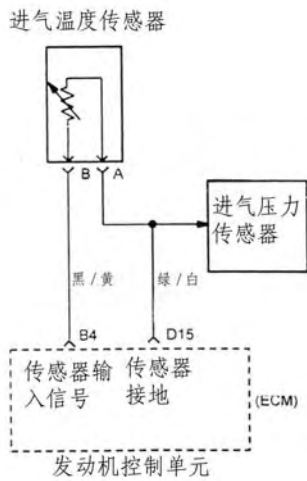

进气压力传感器: Intake pressure sensor

进气温度传感器: Intake temperature sensor

传感器接地: Sensor earth

传感器输入信号: Sensor input signal

发动机控制单元: Engine-ECU

绿/白-GW

黑/黄-BY

FIG. 4-5d)



FIG. 4-5e)



FIG. 4-5f)

3) Knock sensor (Fig. 4-6)



A sensor which is installed on inlet side of upper middle of 4th cylinder, supplies information about knock to achieve closed-loop control of knock.

Using ohmmeter, measure resistance between terminals 1 and 2, which should be more than 10MΩ. Resistance between terminal 2 or terminal 3 and ground should be 0Ω.

Fig. 4-6

4) Coolant temperature sensor

A device is installed on cycling water route of inlet manifold, offer coolant temperature information to correct the amount of fuel injection and ignition timing, see fig. 4-7a).



The sensor responds to engine coolant temperature and product voltage signal which is transmitted to ECU to control injecting quantity and ignition timing.

Fig. 4-7a)

The sensor is thermo-resistance type. Its resistance decreases with temperature increasing.

For BOSCH M1.5.4, resistance between terminals 1, 2, sees Table 4-1a).

Table 4-1a)

Coolant temperature (°C)	Resistance (Ω)	Coolant temperature (°C)	Resistance (Ω)
50	740~900	80	290~360
60	540~650	90	210~270
70	390~480	100	160~200

For DELPHI system, the principle diagram sees Fig. 4-7b, resistance sees

Table 4-1b)

Table 4-1b)

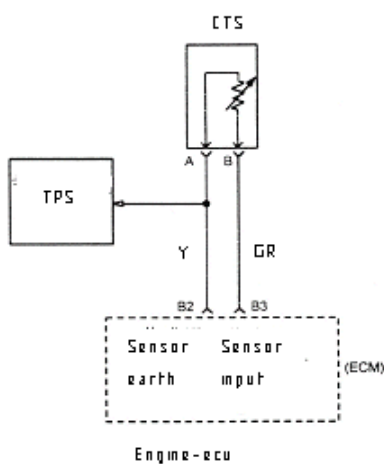

Coolant temperature (°C)	Resistance (Ω)
20	3555 ± 3.6
80	337.9 ± 2.6
100	180.3 ± 2.3

Fig. 4-7b)

5) Rotation speed sensor

For BOSCH M1.5.4 system(fig.4-8), the sensor is a Hall sensor, which is installed in distributor to supply information about engine speed and crankshaft phase which is used as reference to timing for injection and



Fig. 4-8

ignition. When adjusting TDP of 1st cylinder, scale on fly wheel should be on 0 degree, distributor should be located as shown in Fig.4-8, which low end of gas before hole in rotor should be along with the middle of HALL sensor. At this time, the ignition advance angle should be  $6^{\circ} - 7^{\circ}$ .

6) Oxygen sensor



Fig. 4-9a)

A sensor (fig.4-9a) is installed on exhaust manifold to offer signals about mixture concentration to correct injecting quantity, which achieves closed-loop control of air/fuel ratio.

The sensor responds to oxygen concentration in exhaust and product voltage signal that is transmitted to ECU. With low air/fuel ratio, oxygen concentration in exhaust is high, which high voltage signal occurs, see fig.4-9b).

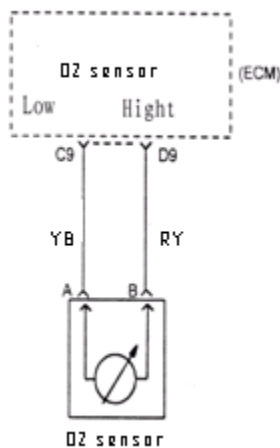

Fig 4-9b)

For BOSCH M1.5.4 system, ECU power the sensor with voltage of 12-14V.

Inside resistance: ignition switch OFF. Disconnect oxygen sensor connector. Measure resistance between tow white leads, which the value should be  $0.2\Omega \sim 20\Omega$  (change with temperature).

For DELPHI system, output voltage is 750mV (rich) - 150mV (lean) /400°C.

7) Crankshaft position sensor

A sensor which is used by DELPH system is installed on the backside of

cylinder head (Fig4-10a)), offer information of engine speed and crank phase signal which is used as reference for timing of injection and ignition. The sensor responds to crank angle. A speed signal pan is fixed on fly wheel, with 60-2 teeth. When the pan rotates, pulse signals is provided on crankshaft position sensor and is transmitted to ECU to indicate crank angle and engine speed as shown in Fig 4-10b).

Output voltage range:  $\geq 400V/60r/min$

Coil resistance:  $540 \Omega \pm 50 \Omega / 25^{\circ}C \pm 5^{\circ}C$

Gap between the sensor and signal pan: 0.5~1.75mm.



Fig. 4-10a)

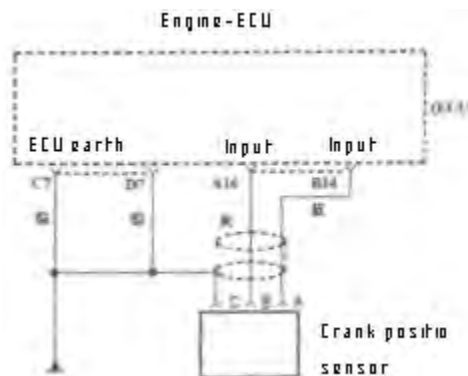

Fig. 4-10b)

● **Actuators**

- 1) **Electronic fuel pump:** Be installed in fuel tank, ECU controls fuel pump work with fuel pump relay, once engine stop working, electronic fuel pump stop automatically. The pump keeps fuel pressure on 300kPa

NOTICE  
Not disassembly fuel pump to prevent from explosion for damaging seal part.

- 2) **Fuel injectors:** Be installed on the fuel rail assembly (Fig4-11a), it inject fuel toward air passage by ECU control. The open period of needle in injector is controlled by means of magnetic field which is signaled by ECU , which decides injecting quantity. Fuel pressure keeps constant by pressure regulator when vacuum in inlet manifold changes.



Injector operation voltage: 12V

Coil resistance:  $15.9 \Omega \pm 0.35 \Omega$  (BOSCH M1.5.4 system)

$12 \Omega \pm 2 \Omega$  (DEHPHI system)

Fig 4-11a)

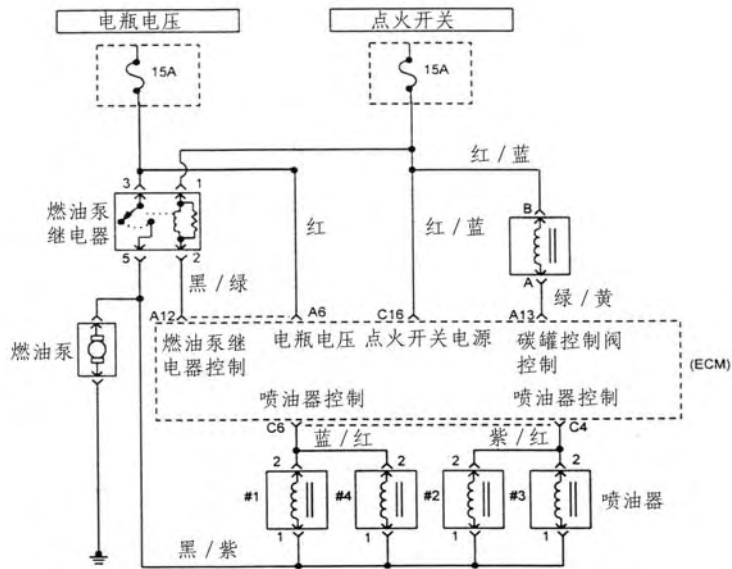

Fig. 4-11b)

- |                     |               |
|---------------------|---------------|
| 蓄电池电压-Battery       | 黑/绿-BG        |
| 点火开关-IG             | 红-R           |
| 燃油泵继电器-F/pump relay | 红/蓝-RL        |
| 燃油泵继电器控制-F/pump     | 绿/黄-GY        |
| 点火开关电源-IG           | 蓝/红-LR        |
| 碳罐控制阀控制-Purge       | 紫/红-VR        |
| 喷油器控制-INJ.          | 黑/红-BR        |
| 喷油器-Injector        | 燃油泵-Fuel pump |

3) Ignition coil



Fig. 4-12a)



Fig 4-12b)

For BOSCH M1.5.4 system, ignition coil (Fig.4-12a) primary circuit opens or closes, which is controlled by ECU. The bracket of ignition coil should ground reliably.

For DELPHI MT20 system (fig.4-12b), ignition mechanism without distributor is used. Ignition signals to the dual ignition coils is driven by drive circuit in ECM. Four posts on the ignition is connected to sparks respectively, which one coil controls sparks of 1-4 cylinders and the other controls sparks on 2-3 cylinders. A voltage of 5V which ECU offers powers the primary circuit. When ECU cut off the power, (cut current of the primary circuit), high voltage is inducted on the secondary circuit, which is transmitted to sparks to fire as shown in Fig. 4-12c).

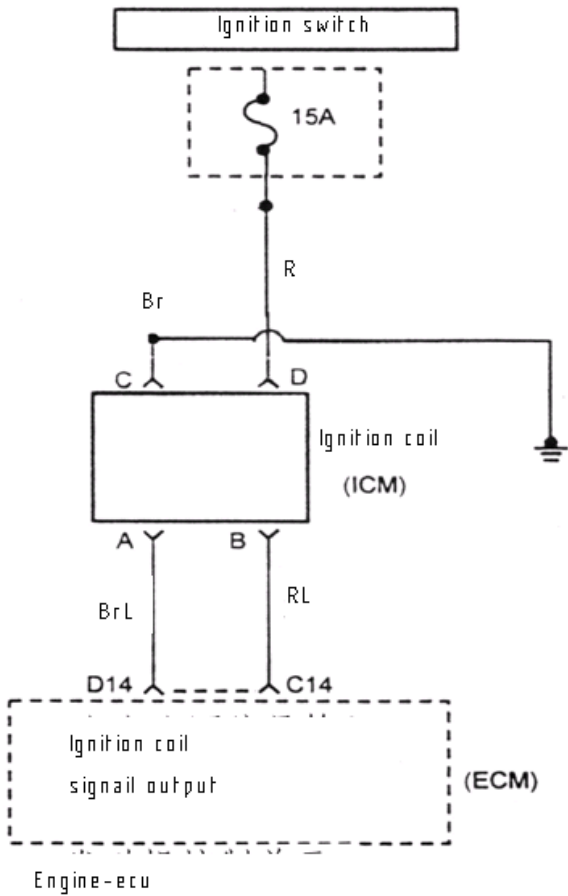

Fig. 4-12c)

Primary windings resistance:  $0.5\Omega \pm 0.05\Omega$

Inductive voltage in primary windings: 414V

Secondary windings resistance:  $5100\Omega \pm 300\Omega$

Inductive voltage in secondary windings: 37.1kV.

4) Idle adjuster (stepper motor): Be installed on the throttle body assembly. ECU controls its action and change section of by-pass path, and change the amount of by-pass air to control idle speed.

For BOSCH M1.5.4 system ( Fig.4-13a), resistance of coil is  $17.7\sim 20.0\Omega$

For DELPHI MT20 system (Fig.4-13b, Fig. 4-13c), steps of step motor change in a range of  $0\sim 255$  Steps.



Fig. 4-13a)



Fig. 4-13b)

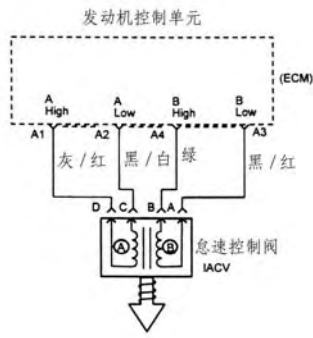

Fig. 4-13c)

发动机控制单元—Engine-ECU

怠速控制阀-Idle adjustor

灰/红-GrR

黑/白-BW

绿-G

黑/红-BR

5) Canister purge valve (BOSCH system sees Fig4-14a, DELPHI system sees Fig4-14b): Be installed on coupling portion of transmission and block. ECU control its opening degree to control the amount of clean air flow from canister to inlet manifold.



Fig. 4-14a)



Fig. 4-14b)

For DELPHI system, Coil resistance (Fig. 4-14c):  $21.8\Omega \sim 28.5\Omega / 20^\circ\text{C}$

Operation voltage: 8~16V

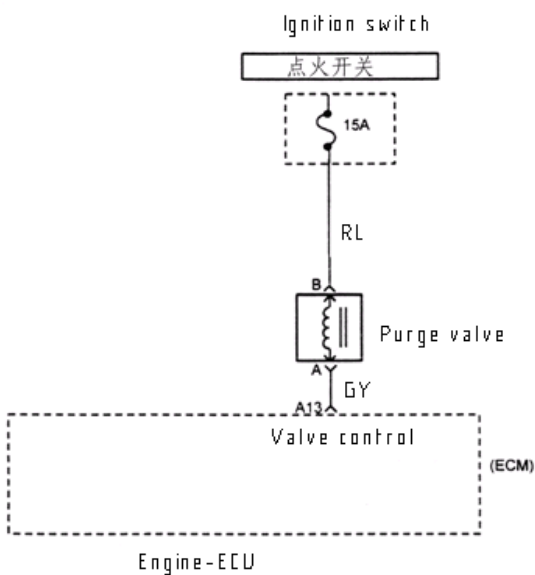

Fig. 4-14c)

- **Electronic control unit (ECU)**

ECU (BOSCH system sees Fig4-15a, DELPHI system sees Fig.4-15b) sends order to actuators after analyzes the input signals of sensors.

ECU should be installed in rainproof and hypothermal position.



Fig14-5a)



Fig14-15b)

### 4.3 Engine' s inspection

The following parts or components do not require engine removal to receive services (replacement, inspection or adjustment), see table 4-2:

Table 4-2

Part or Component	correction
① Spark Plug	Replace or inspect
② Distributor	Replace or inspect
③ Exhaust Manifold	Replace
④ Oil Filter	Replace or inspect
⑤ Oil Pressure Sensor	Replace
⑥ Valve Chamber Cover	Replace
⑦ Rocker Arm Shaft	Replace or inspect
⑧ Rocker Arm	Replace or inspect
⑨ Rocker Arm Spring	Replace or inspect
⑩ Camshaft	Replace or inspect
⑪ Cylinder Head	Replace or inspect
⑫ Radiator	Replace or inspect
⑬ Camshaft driven synchronization gear	Replace
⑭ Crankshaft drive synchronization gear	Replace or inspection
⑮ Crankshaft drive timing gear	Replace or inspection
⑯ Timing chain	Replace

17 Oil pump	Replace
18 Throttle body	Replace or inspect
19 Inlet manifold	Replace
20 Alternator	Replace or inspect
21 Starter	Replace or inspect
22 Triangle belt for radiation fan.	Replace, inspect or adjust
23 Water pump	Replace or inspect
24 Chain pulley ( crankshaft, generator, water pump )	Replace
25 Synchronization chain cover	Replace
26 Cooling hose	Replace or inspect
27 Oil pump, piston, piston ring and connecting rod	Replace or inspect
28 Fuel rail, injectors	Replace or inspect
29 Fuel hose	Replace
30 PCV	Replace or inspect
31 Sensors	Replace

#### 4.4 Engine Removal

- Remove service panel on floor panel
- Remove the guard stone under the engine;
- Unscrew the water drain plug of the radiator and cylinder , drain off coolant.
- Disconnect the negative wire from battery;
- Disconnect the positive wire from battery;
- Disconnect the connector of backup lamp switch;
- Remove flexible shaft of odometer from transmission.
- Remove water inlet and outlet hose of the heater.
- Disconnect the high tension cable from ignition coil.
- Disconnect lead from water temperature gauge.
- Disconnect sensors and actuators, the sensors and actuators see Table 4-2:

No	Item	Location	Mark
1	Intake temperature/ pressure sensor	Inlet manifold stable pressure chamber	
2	Throttle position sensor	Throttle assembly	
3	Knock sensor	Intake side of cylinder block	
4	Oxygen sensor	Exhaust manifold	
5	Water temperature gauge	Water route on inlet manifold	
6	Oil pressure switch	Outside of block	
7	Rotation speed sensor	Distributor	
8	Coolant temperature sensor	Inlet manifold	
9	Injectors	Fuel rail	
10	Idle adjuster(step motor)	Throttle assembly	

- Disconnect positive wire of alternator;
- Remove A/C pipes from compressor according to A/C removal procedure
- Disconnect acceleration cable from throttle body assembly;
- Disconnect injectors.
- Disconnect crankcase bleed pipe from air filter;
- Disconnect intake hose from throttle body assembly;
- Disconnect inlet and return fuel hoses from fuel rail assembly;

**Caution**

Because pressure in the fuel pipes is very high whenever the engine stops, disconnect fuel hose after draining fuel, in order to avoid fuel from ejecting and danger happening.  
Remove on a place which is far from fire source.

- Disconnect water inlet and outlet hose from radiator.
- Disconnect cable of clutch from engine and clutch lever..
- Remove muffler from exhaust manifold and body frame.
- Remove drive shaft;
- Disconnect gear shift control cables from selector and shift arm on the transmission
- Disconnect leads (YB and +) from startor
- Disconnect battery negative lead from transmission case
- Remove the cover of radiator;
- Support engine and transmission;
- Remove connecting bracket of transmission from vehicle frame;
- Remove engine member assy. from vehicle frame;

### Caution

Inspect all connectors around the engine again; be sure all parts are removed before removing the engine.

## 4.5 DISASSEMBLY OF ENGINES

The content refers to 《HFJ6351B service manual》 .

### 4.6 Service on engine

#### 4.6.1 TROUBLESHOOTING FOR ENGINE OF EFI

Gasoline electronic control system is very complexity. Every trouble, such that part faulty, lead cut off, terminal separated or connect poor, lead to whole system malfunction. It is impossible for conventional tools to service. So a system, which is known as built-in self-diagnosis system is equipped in gasoline electronic control system. Tester specified for gasoline electronic control system is used for troubleshooting.

In principle, when a trouble related to engine electronic control fuel injection system is been inspecting, first you should act just like for conventional engine( without EFI ), which check for mechanism trouble. Especially when service light in meter doesn't light., engine should be inspected , just like the engine without ECU, on basic procedures.

### CAUTION

Be sure that there are no trouble on mechanism portion before inspecting EFI, or in case of a single trouble which isn't related to EFI, you inspect sensors, actuators and ECU, so that you spend a lot of time but cannot leave out the trouble.

#### ● Without the tester

##### 1. Basic tools

multimeter, rotation speed meter, fuel pressure meter, vacuum meter.

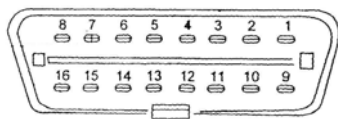

Fig.4-16

##### 2. Read DTC (diagnosis trouble code) (FIG.4-16)

- 1) Connect the connector within vehicle to diagnosis connector as shown in left figure (BOSCH).
- 2) Service light in meter should flash.
- 3) Repair according to DTC.
- 4) There are several seconds between digits. If there are more than tow DTCs, the light flash for three times before next DTC is shown, see table4-3.

DTC	Flashing number
	10
1	1
2	2
3	3
4	4
5	5
6	6
7	7
8	8
9	9

- **With the tester**

The tester is able to show input/output signals, test actuator to offer convenience for diagnosis. When ECU receives abnormal signals or referential voltage, it will remember DTC of the fault after judging, and transmit to the tester that is connected to diagnosis connector, which reads the DTC.

Memory of DTCs is powered with battery, so DTCs continue to be kept even when ignition switch OFF. The memory will be eliminated when lead of battery or ECU connector is disconnected.

Model of the tester used for M1.5.4 system is S.W.G99-02. Read User Manual of the tester carefully before using.

- **Points for Diagnosis**

The tester is used mainly to inspect faults of engine electronic control system. The time which is spent on troubleshooting will reduce greatly if the tester is used properly.

It is convenient to inspect most faults by means of the tester, but it is impossible to solve any trouble with the tester.

In general, it is not a single program to find causes of trouble symptoms. So a lot of knowledge is needed about engine electricity and mechanism. Diagnosis troubleshooting should be done from simple reasons to difficult reasons, such that connectors connect poorly, fuse of EFI is blown, leakage occurs in inlet system. If the trouble continues after inspecting single reasons, use the tester.

The method will reduce diagnosis period of single troubles.

- **Conditions when using the tester**

(1) Battery voltage: >8V

(2) Fuse is normal.

(3) Ground lead of engine is connected properly.

(4) Ignition switch: ON

(5) Must drive for more than 4 min before reading DTCs for any trouble related regulation of air/fuel ratio.

- **Remove general troubles**

Basic tools: tester, multimeter.

Which is inspected below should be the trouble which symptoms continue after removing mechanism faults, which is related with EFI system.

## Inspection for trouble symptoms

### 1) No starting

#### Means

(1) Does service light in meter light or not when Ignition switch ON ?

A. Not

- check fuse and ground lead;
- Check ECU connector;
- Test service light and its circuit with the tester;
- Inspect and repair the bulb and its circuit;
- Replace ECU.

B. light

- Connect the tester to diagnosis connector

(2) Can the tester communicates with the system or not?

A. Can't

- Check fuses and ground leads;
- Check ECU connector;
- Check the tester condition when it is used in a vehicle in normal condition;
- Replace ECU.

B. Can

- Remove troubles according to indications of the tester.

(3) Can sparks fire normally or not? –Ignition system check

A. Can't

- Check tension cables and sparks for coupling condition, such as damage or unproper;
- Check after replacing ignition coil;
- Check after replacing ECU

B. Can.

- Check connection of ignition coil and cylinders for order with tension cables;

(4) Fuel supply system check

1) Check order of inlet and outlet fuel pipelines;

2) Does fuel pump operate or not? – Listen to sound near fuel tank when engine operates

A. not

- Check fuel pump relay and its circuit;
- Check Hall sensor and its connection;
- Replace ECU
- Check fuel pump circuit.

B. operate

- Check whether fuel pressure is more than 0.25Mpa;

poor pressure:

- Check fuel filter, replace if necessary.
- Check inlet and outlet fuel pipeline;

- Check fuel pressure;
- normal pressure:**
- Check control circuit of injectors;
- Clean injectors if necessary ( once every 15000km).

## 2) Poor idling

### No idling

#### Methods

- Check idling adjuster
- Check circuit and connectors of idling adjuster;

### Engine racing during idling

#### Methods

#### 1) idle control system check

- Check connector of idle control solenoids.
- Check that steps(50 – 159) of idling adjuster is in range and change in small level;
- Raise the steps for more 50 steps using the tester test actuator function of the tester.

Check whether engine speed rises .

✧ If rises, stop engine, disconnect battery lead for 3 min, restart the engine.

✧ If no rise, replace throttle assembly.

#### 2) Supply system check

- Check vacuum hoses for fuel regulator on fuel rail for connection and damage;
- Clean injectors if necessary.

### Speed is too high in idling

#### Methods

It is normal condition if coolant temperature is lower than 68°C or higher than 98°C. ECM raises idling speed to warm engine when coolant temperature is lower than 68°C. ECM raises idling speed to increase radiator capability when the temperature is higher than 98°C. Any trouble that is other than the tow conditions should be checked in following steps:

- Check that steps(40 – 159) of idling adjuster is in range and change in small level;
- ✧ If steps change in too small level, check vacuum hoses on inlet manifold for connection and plug.
- Reduce the adjuster for 30 steps with actuator test function of the tester. Check whether engine speed reduces too.
- ✧ If engine speed doesn't reduce, replace throttle assembly.

#### 3) Poor acceleration

- Check fuel filter for jam;
- Check fuel pressure and injectors;
- Reads on the tester is in normal range in idling or idling in high speed;
- Gas of crankshaft position sensor (DELPHI) is too big.

## Inspection for intermittent malfunction

### (1) Inspection for parts not related to electrical circuit

- Must perform general service before doing the inspection. You can find trouble places usually with eyes, with shortened time. Inspection follows steps below:
- Check ground places for ECU and be sure these places cleanly and steadily..

- Check vacuum hoses and its coupling places to avoid leakage because of crack or disconnection;
- Check port places of throttle assembly and air inlet to avoid leakage;
- Check connection of tension cables for steady. Be sure that no cables have cracks or cut. **Remove carbon on sparks**
- **Be sure that all connectors and terminals is connected steadily and properly.**

### (2) Poor connection

Most intermittent malfunction is results of poor connection. Check following places in detail:

- Be sure that harnesses connect and ground properly and steadily.
- Be sure that terminals of sensors are contacted properly and steadily;
- Be sure that connectors of sensors are not damage;
- Be sure that sensors is connected to harness properly and steadily.

### (3) Service light lights intermittently

- If no DTC occurs, check following items:
- ECU ground poorly
- Relays operate poorly. Solenoids in ECU are driven or switched to lead interfere of electronic system;
- Low voltage circuit in ECU and ignition system grounds poorly;
- Circuit of service light or diagnosis connector short intermittently.

### (4) Fuel system

Some intermittent malfunctions is results of poor fuel. If engine stops suddenly or other malfunctions occur, ask users for fill:

Is the vehicle filled at same station? Is the vehicle fill with cheap fuel? If the answer is YES, may there is problem of fuel quality. Check fuel tank to look for deposit, water and other impurity.

## DTCs for UAES system

Table 4-4

DTC	Description	DTC	Description
61	1st step motor solenoid	33	Over limit of engine speed
62	2nd step motor solenoid	34	ECM faulty
14	Throttle position sensor	35	Self-learn of air/fuel ratio-dtv
22	1st injector	36	Self-learn of air/fuel ratio-fra
23	2nd injector	37	Self-learn of air/fuel ratio-tra
24	3rd injector	17	Oxygen sensor
21	4th injector	18	Air temperature sensor
31	Correct value of air/fuel ratio	19	Coolant temperature sensor
15	Knock sensor	25	Purge valve
16	Air pressure sensor	38	Battery voltage
45	Service light		
11	No trouble		

General troubleshooting diagnosis can follow steps below

- a. Ask user for trouble symptoms, on which conditions the trouble occurs, if the trouble has been removed before etc.
- b. Check and judge if the trouble is related to mechanical parts. If it is, repair it.
- c. Inspect whether the trouble symptom disappears. If it is, end service. If not, the trouble may be related with EFI system, which should be removed.
- d. Read DTCs and locate troubles with DTCs.
- e. Be sure that all troubles have been removed. If not, do again. If it is, end.

#### CAUTION

Information of troubles which self-diagnosis system offers only suggests which portions have trouble, but these can not indicate which trouble occurs clearly. For example, when ECU records one trouble that the sensor value is out of limits, it is not to say that the sensor has damaged, it is possible that it results of open or short circuit.

#### 4.6.3 POINTS FOR SERVICE OF EFI SYSTEM

### ● POINTS TO PAY ATTENTION TO WHEN SERVICING EFI SYSTEM

#### At a time of use

(1) ECU is a précis device. Even if many malfunctions is related to ECU, the device by itself has very low malfunction ratio. So don't deal with it or open its connector before you are sure that circuits and parts that is related to trouble isn't problem.

(2) It often occurs that circuits open or connect poorly for electronic system. Besides some open /disconnected circuit, loosened connectors which can be found directly, poor circuits can be inspected with high-resistance multimeter to measure voltage and resistance. Forbid to check circuit for continuity by means of firing between spark plug and block. Because when spark occurs between spark plug and block instantly, a self-induction voltage may occur in **solenoid to electronic elements**.

(3) **Don't disconnect any electric device to prevent electronic elements from damage by inductive voltage when ignition switch ON.**

(4) **Must pay attention to following items when disconnecting battery:**

① **Must turn off ignition switch. If battery is disconnected while ignition switch ON, the dangerous degree for striking electronics elements is greater than condition 2, 3. Because in conditions 2, 3, battery is used as a big capacity to absorb self-inductive voltage in order to protect. There are no protection when battery is disconnected.**

② **Inspect DTC. If there are DTCs. Write the DTCs before disconnecting battery, because unsolidified information in ECU will disappear when battery is disconnected.**

③ **Know the number of audio with thief-proof before battery is disconnected. Or it is difficult to unlock audio system self-lock and make effect to use.**

(5) **If engine operates poorly after battery is disconnected, comparing to engine operation before, not replace any part promptly. Because memory of learn-correction will disappear when battery is disconnected. ECU control by data stored in ROM, which is different from actual learn-correction control. In this case, engine operates for a while to build in learn-correction memory by itself, poor drive operation disappear automatically.**

(6) **Distinguish positive and negative poles when battery is connected. Fix coupling**

part properly and steadily. Otherwise, bad effect to electronic device will product.

(7) Keep elements and connectors of electrical system from water when washing, especially ECU to prevent from short circuit, leakage current, rusty,

(8) Disconnect ECU from battery while repairing with arc welding, Must disconnect ECU while operation of welding is close to it.

(9) Pay attention to learn-correction when ECU is serviced. For instance, while you remove or install PROM., test inside features using multimeter, a metal strap wrap hand on one end and ground on other end to shield learn-correction.

(10) Don't connect or disconnect any device in case that circuit construction isn't known clearly, to avoid malfunction by man.

- Points for use and service of EFI system

1. Leakage in inlet system have more effect to engine with EFI than that with carburetion. Because leakage air isn't measured for EFI engine, a great effect will generate to air/fuel ratio. So at any time that engine operates poorly, check throttle assembly, canister air valve, idling adjuster and exhaust gas recycling for looseness, and air hoses and its ports for leakage. Besides these, check oil scale and oil-filled lid for seal.

2. Because fuel pressure continues after engine stops, so prevent fuel from spraying when you remove fuel lines to lead to danger. Put a pan below before fuel couplings is removed, and lead fuel to the pan with a towel.

3. Seal-washer on fuel lines can only be used for one time. Don't use seal-washer on fuel lines repeatedly..

4. Don't damage new o-rings to make effect to injector seal while installing injectors. Lubricate o-rings with gasoline and it is forbidden to lubricate with oil or gear oil.

5. In general condition, Do not operate the adjusting screw on throttle assembly. Because power performance of engine will decrease and fuel consumption will increase if the screw is adjusted improperly.

6. The performance of coolant temperature sensor may change after the sensor have been used for long period. The coolant temperature signal will be inaccurate, which infect fuel injection, ignition timing and fuel pump. The change of the feature isn't distinguished with self-diagnosis system. So when engine operates poorly, such as no starting, idling poor, high fuel consumption, and no DTC of coolant temperature occurs with self-diagnosis system, check coolant temperature sensor.

7. Do not drop oxygen sensor or collide it with other things when the sensor is checked. Do not cool the sensor with water. Apply specified adhibition-proof glue to the sensor on case of replacing it to prevent removal from the difficulty next.

- Points for use and service

1. Do not touch the ignition coil and the tension cables with hand when the engine is started and operates to prevent from being injured with high voltage.

2. It is best to use insulation rubber to clip tension cables when you do high-voltage firing. It is easy to produce electric strike if tension cables is touched with hand directly. Person will feel uncomfortable even though it do not injure person. The person of operation often throw away the tension cables as soon as electric strike generates to make the high-voltage circuit opened, which the highest voltage generates when the secondary circuit opens. The highest voltage is 3-4 times higher than ignition voltage, which damages ignition high voltage circuit.

Method which avoid electric strike is that the tension cable is inserted to an assistance spark plug, and then the spark plug is grounded , last observe spark condition between the electric poles when high voltage firing is done.

3. When each cylinder operation is checked with cutting off fire in order, ground the tension cables of which cylinder is cut off, with same cause as 2.
4. Ignition timing has great effect on the engine operation. So do not forget to check ignition timing when the engine operates badly, or after engine overhaul.

- Referent data for engine diagnosis

Purpose: supply standard data during engine troubleshooting (Table4-5)。

Conditions: after engine warms and controlled with closed-loop pattern,, engine operates without any load such as air condition, lights.

#### BOSCH M1.5.4 system

Table 4-5

Items	Operation condition or unit	Standard value at idling
Real engine speed	r/min	850 ± 50
Projected speed	r/min	850
Battery voltage	V	12~14
Fuel pump relay	Work or not	Work
TPS signal	Open degree %	0
MAP	hPa	350~650
Inlet air volum	kg/h	6~12
Coolant temperature sensor	°C	80~90
Load	ms	1.8~3.0
MAT	°C	20~70
Air/fuel ratio control integrator xfr		-5% ~ 5%
Air/fuel ratio control self-adapted value xfru		0.95~1.05
Air/fuel ratio control self-adapted value xtru		120~140
Air/fuel ratio control self-adapted value zdtv		128
Injector on-time	ms	4~7
Spark advance angle	degree	5~10
Oxygen sensor	V	0.2~0.8
Closed-loop mode	Opened/closed	closed
Idling control	Work or not	Work
Idling adjustment	Steps	60~100
Duty ratio of purging		0

#### 4.7 Engine Reassembly

The content refers to 《HFJ6351B service manual》 .

## 4.8 Engine inspection and adjustment

The content refers to 《HFJ6351B service manual》 .

## 4.9 Engine lubrication

The content refers to 《HFJ6350B service manual》 .

## 4.10 Maintenance of PCV valve of crankshaft case

PCV valve is composed of valve body, valve, valve cap and spring. It can not be disassembled. Its main function is to direct the air in crankshaft case to intake manifold and there is little quantity of air passing through air cleaner and PVC valve into intake manifold, thus avoiding poor combustion and worsening exhaust etc. Remove and clean it with unleaded gasoline, then dry with compressed air every 5000 km. Push the valve with a fine steel wire and it should move freely. Replace PCV valve if the valve is seized or there is blockage.

## 4.11 Reassembly of engine

1. Lift engine assembly (including gearbox assembly) and put them on the vehicle. Tighten the nuts for LH and RH suspension of engine, the bolts for rear suspension and the holding bolts for engine bracket.
2. Reassemble other parts in the reverse order as for disassembly:
  - 1) Adjust accelerator cable and clutch control cable.
  - 2) Adjust gearshifting cable so that gear shift is smooth and free. Refer to associated sections in chapter 12.
  - 3) Tighten the bolts and nuts to the specified torque. Refer to associated chapters.
3. Refer to associated chapters for accelerator and gearbox's gear oil, engine oil and coolant.
4. Check again that all removed and disassembled parts are reassembled to their original positions prior to engine start.
5. Start the engine and check the timing of ignition. If the requirement is not satisfied, adjust as specified in chapter 8 of this manual.
6. After starting the engine, check if there is any oil leakage, unusual noise and other defect. Also check the work of each part.

## 5 AIR CLEANER, FUEL PUMP AND FUEL FILTER

### 5.1 Electric fuel pump, fuel filter and lines

#### ● General description

The main components of the fuel system are fuel tank, electric fuel pump and fuel filter and it includes three lines: fuel feed line, fuel return line and fuel vapor line.

#### 1. Electric fuel pump (fig.5-1)

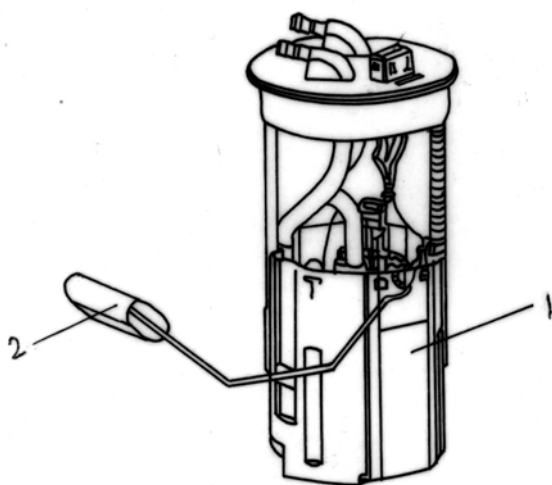

1. Electric fuel pump 2. Fuel level gauge float

Fig.5-1

The electric fuel pump feeds fuel from the fuel tank to the engine, and supplies enough fuel pressure and fuel.

The fuel pump is vane pump driven by direct current motor, and the supplier of fuel pump is UAES. It is fixed in the fuel tank, and dipped in the fuel, and cooled and lubricated by the fuel. The battery supplies power to the pump by pump relay, and the relay can switch on the pump circuit only when engine starting and running. So when the engine stops by accident, the pump stops automatically.

There is fuel level sensor on the pump, and it can measure the level of the fuel in fuel tank. The pump is installed in the fuel tank, and this mode makes the fuel feed

system simple, and it is difficult that the vapor lock and the fuel leakage occur. The pump is installed by flexible mount, and it can reduce the vibration to transfer to the pump.

### Caution

The electric fuel pump can work only when there is enough fuel in the fuel tank. If there isn't fuel in the fuel tank, the pump will burn out due to poor cooling. Therefore, when the engine running or the vehicle moving, there must be enough fuel in the fuel tank. The filled fuel is not less than eight litres when the car is filled for the first time or the fuel in the fuel tank is fully run out in order to keep the level of the fuel in the fuel tank over the level of the inlet of the reserve cup. Then the inlet of the pump in the reserve cup is dipped in the fuel fully, the vehicle can start successfully.

## 2. Fuel filter (fig. 5-2)

The fuel filter is fixed on the inner side of right member.

The fuel comes in the fuel filter from inlet, pass through the filter element and then enter the fuel feed line to the engine through the outlet. The fuel filter is of cartridge type, and does not permit disassembly. The diameter of the filter inlet is same as the outlet, the material of the filter case is metal, and the filter case is welded to whole body at the middle flange.

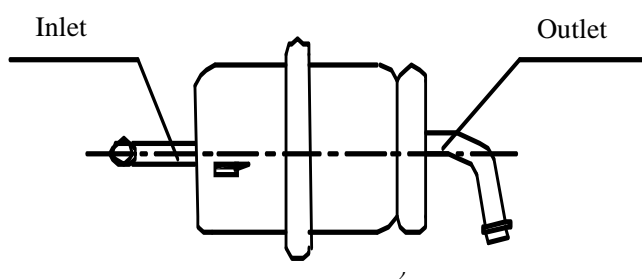

Fig.5-2

● Removal and installation

1) Notice

Before attempting service of any type on the fuel system, the following cautions should be always observed.

- (1) Disconnect negative cable at battery.
- (2) Do not smoke and place “NO SMOKING” signs near work area.
- (3) Be sure to have CO<sub>2</sub> fire extinguisher handy.
- (4) Wear safety glasses.
- (5) To release the fuel vapor pressure in fuel tank, remove the fuel filler cap from fuel filler neck and then reinstall it. If the pressure in fuel tank is not released beforehand, the fuel in fuel tank may come out from the fuel hoses due to the pressure when they are disconnected.

2) Operations

◇ Electric fuel pump

• Removal

- a) Disconnect negative cable at battery.
- b) Remove the fuel filler cap from fuel filler neck to release the fuel vapor pressure in fuel tank. After releasing, reinstall the cap.
- c) Raise the vehicle.
- d) Disconnect cable at electric fuel pump.
- e) Drain the fuel by removing the drain plug.
- f) Disconnect the fuel feed hose, fuel return hose, fuel vapor hose and ventilation hose of fuel filler neck on fuel tank from connecting metallic pipes and canister joint, and drain the remaining fuel into a vessel.

**Caution**

**Recheck whether all hoses and cables have been removed or not before removing the fuel tank.**

- g) Remove the fuel tank.
- h) Disconnect the inlet hose, outlet hose, return hose and vapor hose on electric fuel pump.
- i) When removing the fuel pump, remove the nuts, and take down the retainer and then take out the fuel pump from the fuel tank.

●Inspection

a) Check the electric fuel pump

After the fuel pump taken out, dip it into gasoline (must be in fire protection environment), and switch on the power (voltage range: 6~ 13V). Caution: “1” connect to the positive terminal of fuel pump, and “4” connect to the negative terminal of fuel pump, and visually inspect whether the fuel comes out from the outlet hose or not. If the fuel pump is operational, the fuel comes out, and otherwise the fuel pump is faulty.

b) Check the fuel level sensor

After taking out the fuel pump, use multimeter and turn to “ohm” position. Connect the positive cable and negative cable of multimeter to the corresponding “2” terminal and “3” terminal on the flange of fuel pump, Move the float rod slowly and at the same speed along the float movement direction. Normally, the resistance values should be displayed continuously and variously on multimeter, otherwise it is faulty.

• Installation

It is the reverse procedures as removal. At first install the electric fuel pump(with gasket) to the fuel tank, and then install the retainer, and tighten the nuts following the specified torque.

◇Fuel filter

• Removal

1. Disconnect negative cable at battery.

2. Remove the fuel filler cap from fuel filler neck to release the fuel vapor pressure in fuel tank. After releasing, reinstall the cap.
3. Disconnect the inlet and outlet hoses from fuel filter.
4. Remove the fuel filter assembly(with bracket) from vehicle.

• Installation

- (1) Install the fuel filter assembly(with bracket) to vehicle.
- (2) Connect the inlet and outlet hoses to fuel filter.
- (3) Connect negative cable at battery.
- (4) After installing, start engine and check the fuel hoses for leaks.

Caution

Be sure that inlet and outlet must be connected correctly when installing fuel filter, mark “IN” is inlet and mark “OUT” is outlet.

◇Fuel tank

• Removal

Follow the removal procedures of electric fuel pump.

• Purging

Caution

This purging procedure will not remove all fuel vapor. Do not attempt any repair on tank where heat or flame is required, as an explosion resulting in personal injury could occur.

- (1) After removing the fuel tank, remove all hoses and electric fuel pump.
- (2) Drain all remaining fuel from tank.
- (3) Move tank to flushing area.
- (4) Fill tank with warm water or tap water, and agitate vigorously and drain. Repeat this washing until the inside of tank is clean. Replace the tank if the inside is rusty.

(5) Completely flush out remaining water after washing.

• Installation

Follow the reserve procedures of removal.

Notice

- (1) Make sure to connect hoses to pipes correctly.
- (2) Make sure all hoses are secure.
- (3) After installing, start engine and check the couplers for leaks.

● On car service

- (1) Fuel lines

Caution

As the fuel feed pressure is 0.3Mpa(3 atmospheric pressures), the fuel feed and fuel return hoses must use anti-cracking rubber hose, and the fuel hoses must be fastened by clamps, and regularly check the fuel hoses for leaks. When check the fuel lines, prohibit disconnecting the fuel rail inlet and outlet hoses and then start the engine for checking the fuel pump, otherwise the draining fuel can bring fire.

Visually inspect the fuel lines for evidence of fuel leakage, hose cracking and deterioration, or damage. Make sure all clamps are secure. The tightening torque for fuel hose clamps is 3.5~4N.m.

Repair for leaks. Correct the malconditioned hose connections and clamp fixing. Replace the damaged hoses.

Caution

Repair for leaks on condition that the engine and the electric fuel pump must stop running .

## 5.2 Emission control system

### ◇ Fuel vapor control system

The principle is shown in figure 5-3. This system serves to reduce the amount of fuel evaporative emission (HC) to be released into the atmosphere. The vapor generated in the fuel tank while driving or the engine at a stop enters the charcoal canister where the charcoal absorbs and stores the fuel vapor. While the engine is running, the canister electromagnetic valve is opened depending on

outside case (such as engine idle speed) and the fuel vapor stored in the canister is drawn into the intake manifold together with fresh air to be burned. While the engine is not running, the fuel vapor is stored in the canister.

图中文字翻译：

带通气阀的加油口盖：Fuel filler cap with ventilation valve

电动燃油泵：Electric fuel pump

翻车阀：Fuel check valve

燃油箱：Fuel tank

蒸发管：Vapor line

节气门腔体：Throttle body

进气歧管：Intake manifold

炭罐：Charcoal canister

炭罐电磁阀：Canister electromagnetic valve

空气：Air

油蒸汽：Fuel vapor

油气混合气：Air mixed with fuel

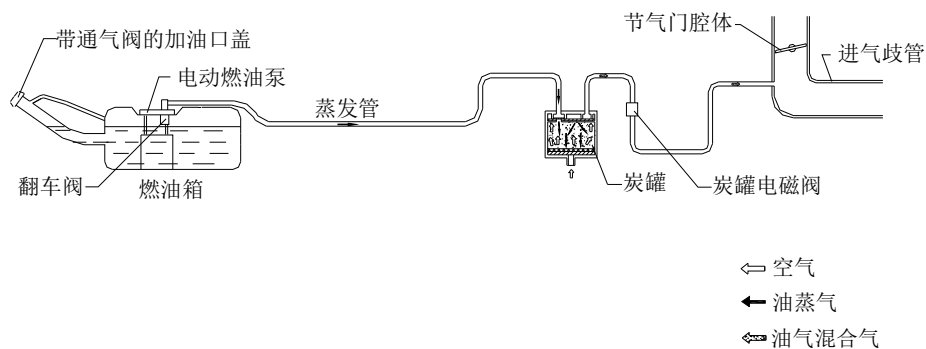

Fig.5-3

## 6 ENGINE COOLING

### 6.1 GENERAL DESCRIPTION

The cooling system consists of the radiator cap, radiator, water reservoir tank, hoses water pump, cooling fan, thermostat.

#### 1) Radiator Cap (fig.6-1)

A pressure-vent cap is used on the radiator. The cap contains a pressure valve and vacuum valve. The pressure valve is held against its seat by a spring of pre-determined strength which protects the cooling system by relieving the pressure if the pressure in cooling system rises by 0.9Kgf/cm<sup>2</sup>. The vacuum valve is held against its seat by a light spring which permits opening of the valve to relieve vacuum created in the system when it cools off and which otherwise might cause the radiator to collapse.

The cap has its face maked 0.9, which means that its pressure valve opens at 0.9kgf/cm<sup>2</sup>.

#### CAUTION

Do not remove radiator cap to check engine coolant level.  
Check coolant visually at the see-through water reservoir tank.  
Coolant should be added only to the reservoir tank as necessary.

#### CAUTION

As long as there is pressure in the cooling system, the temperature can be considerably higher than the boiling temperature of the solution in the radiator without causing the solution to boil. Remove of the radiator cap while engine is hot and pressure is high will cause the solution to boil instantaneously and possibly with explosive force, spewing the solution over engine, fender and rsonremoving cap.

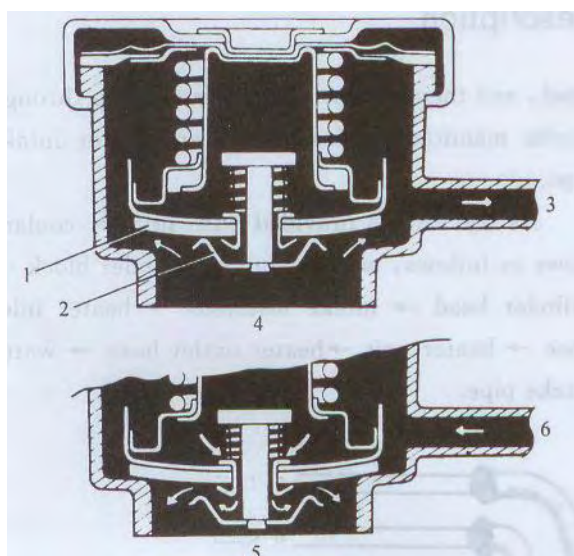

FIG. 6-1

- |                   |                 |                             |
|-------------------|-----------------|-----------------------------|
| 1 Pressure valve  | 2 Vacuum valve  | 3 To water reservoir tank   |
| 4 Pressure relief | 5 Vacuum relief | 6 From water reservoir tank |

2) Water Reservoir Tank (FIG. 6-2)

A “see-through” plastic reservoir tank is connected to the radiator by a hose. As the car is driven, the coolant is heated and expands. The portion of the coolant displaced by this expansion flows from the radiator into the reservoir tank. When the car is stopped and the coolant cools and contracts, the displaced coolant is drawn back into the radiator by vacuum. Thus, the radiator is kept filled with coolant to the desired level at all times, resulting in increased cooling efficiency.

Coolant level should be between “FULL” and “LOW” marks on the reservoir tank. Coolant should be added only to the reservoir tank as necessary

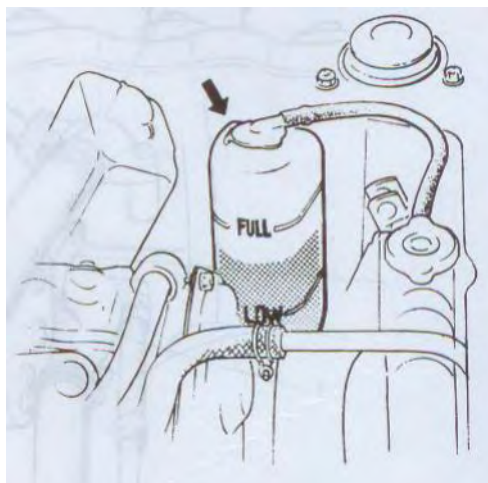

FIG.6-2 (see fig.7-3 of service manual for HFJ6351B)

3) Water Pump (FIG.6-3)

The centrifugal type water pump is used in the cooling system. The pump impeller is supported by a totally sealed bearing. The water pump can not be disassembled.

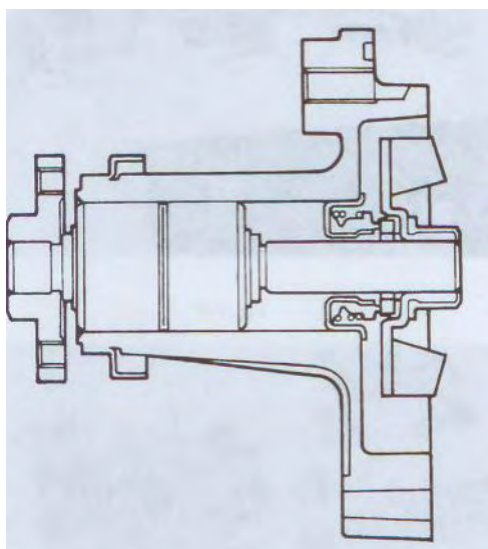
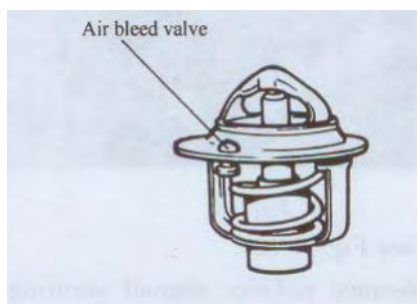

FIG.6-3 (see fig.7-4 of service manual for HFJ6351B)

4) thermostat(FIG.6-4, TABLE 6-1)



排气阀-air bleed valve

FIG.6-4

A wax pellet type thermostat is used in the coolant outlet passage to control the flow of engine coolant, to provide fast engine warm up and to regulate coolant temperatures.

When the pellet is heated and expands, the metal case pushes down the valve to open it.

Thus, the valve remains closed while the coolant is cold, preventing circulation of coolant through the radiator.

At this point, coolant is allowed to circulate only throughout the engine to warm it quickly and evenly.

As the engine warms, the pellet expands and the thermostat valve opens, permitting coolant to flow through the radiator.

In the top portion of the thermostat, an air bleed valve is provided; this valve is for venting out the gas or air, if any, that is accumulated in the circuit

TABLE 6-1

Thermostat functional spec	
Temo. at which valve begins to open	82°C
Temo. at which valve become fully open	95°C
Thermostat valve lift	over 8mm, 95°C

## 6.2 Removal

### CAUTION

Before removing any parts of cooling system, be sure to check coolant for cool.

Before removing any parts of cooling system, be sure to check if negative cable is disconnected at battery.

- 1 ● Coolant Drain (FIG.6-5)
  - (1) Remove Radiator Cap.
  - (2) Remove reservoir tank, and drain coolant.

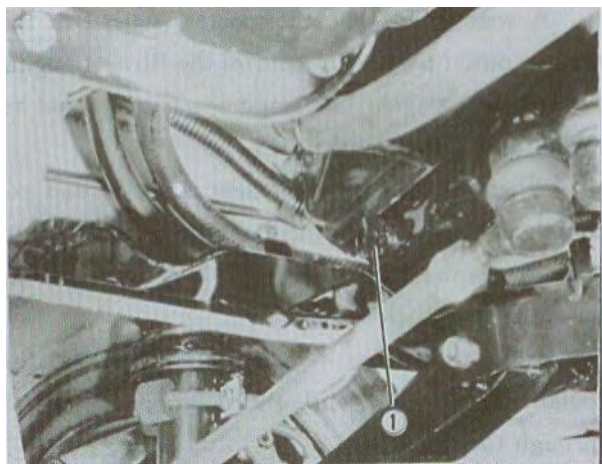

FIG.6-5 (see fig.7-6 of service manual for HFJ6351B)

2 ●Engine Cooling Hoses (FIG.6-6)

- (1) Drain cooling system.
- (2) Loosen clamp of cooling hoses.

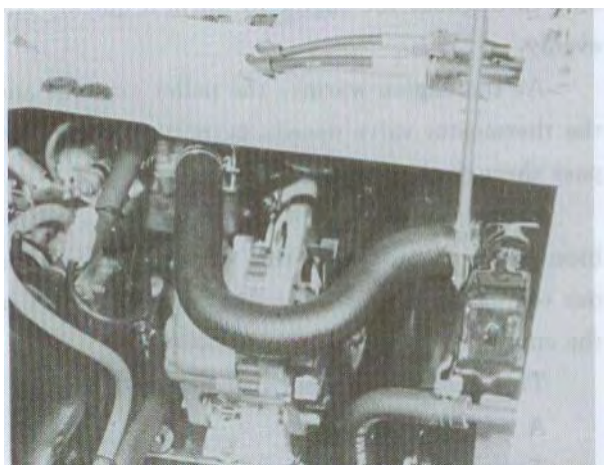

FIG.6-6 (see fig.7-7 of service manual for HFJ6351B)

3 ●Water Pump Belt (FIG.6-7)

- (1) Loosen water pump belt tensioner
- (2) Take down belt.

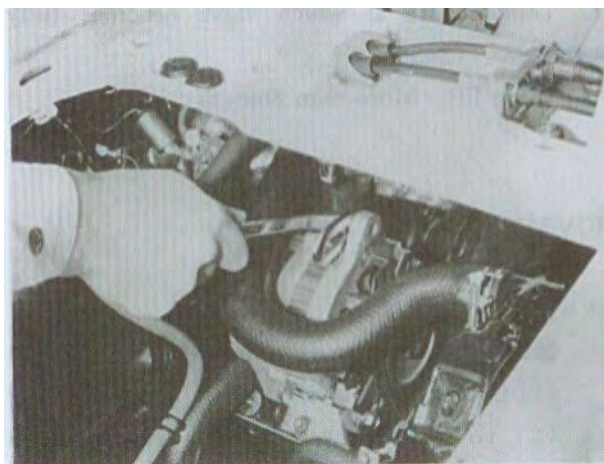

FIG.6-7 (see fig.7-8 of service manual for HFJ6351B)

● Cooling fan removal (FIG.6-8)

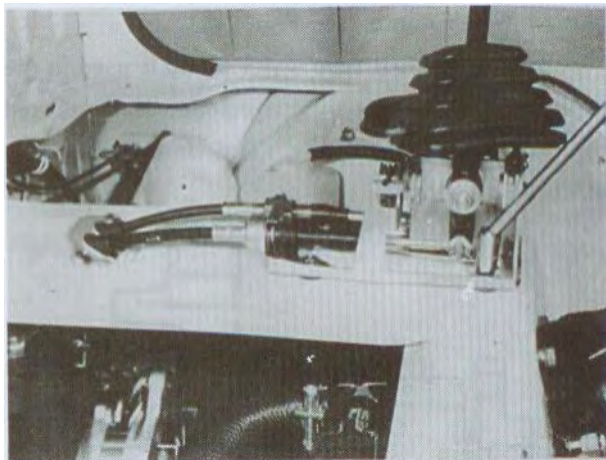

FIG.6-8 (see fig.7-9 of service manual for HFJ6351B)

- (1) Drain cooling system.
- (2) Disconnect gear shift and select cables from shift shaft level and select shaft level. Refer to interrelated section.
- (3) Remove engine room center member.
- (3) Disconnect radiator inlet hose (A), if equippe with brake booster, disconnect vacuum hose. (B) (FIG.6-9).

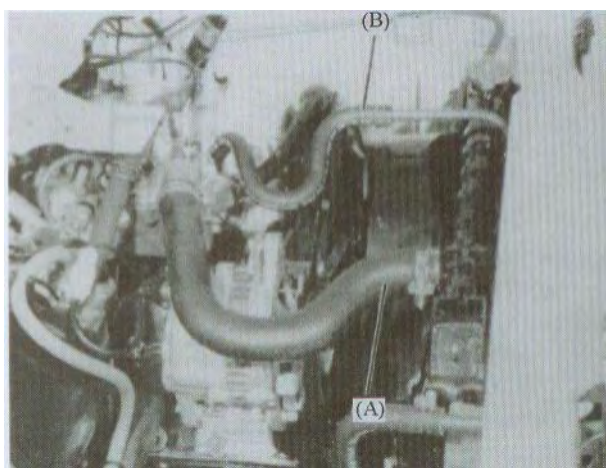

FIG.6-9 (see fig.7-10 of service manual for HFJ6351B)

- (4) Remove radiator shroud securingbolts and cooling fan securing bolts. (FIG.6-10).

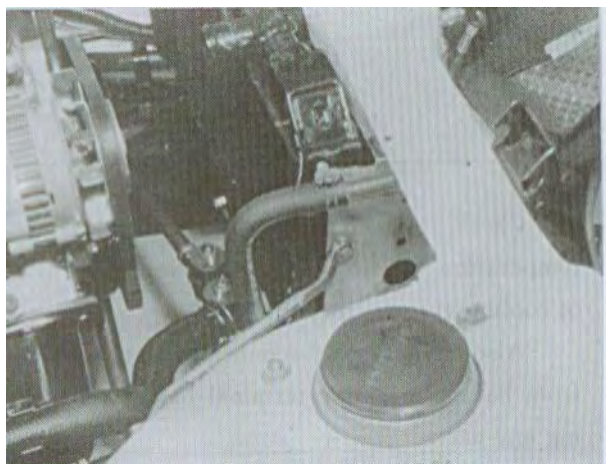

FIG.6-10 (see fig.7-11 of service manual for HFJ6351B)

(6) Then remove cooling fan and radiator shroud.

● Radiator removal (FIG.6-11)

- (1) Drain cooling system.
- (2) Disconnect gear shift and select cables from shift shaft lever and select shaft lever. Refer to section 12-2.
- (3) Disconnect radiator outlet hose from radiator.

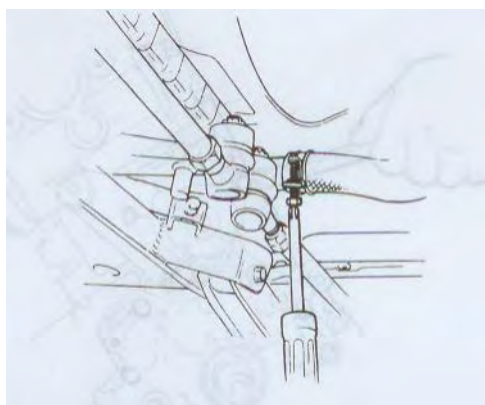

FIG.6-11 (see fig.7-12 of service manual for HFJ6351B)

- (4) Remove engine room center member.
- (5) Disconnect radiator inlet hose (A), if equipped with brake booster, disconnect vacuum hose (B). Refer to cooling fan removal.
- (6) Remove radiator shroud securing bolts and cooling fan securing bolts.
- (7) Then remove cooling fan and radiator shroud.
- (8) Remove radiator.

● Electric Fan Removal

- (1) Disconnect the wiring.
- (2) Remove electric fan screw.
- (3) Remove electric fan.

● Thermostat Removal (FIG.6-12)

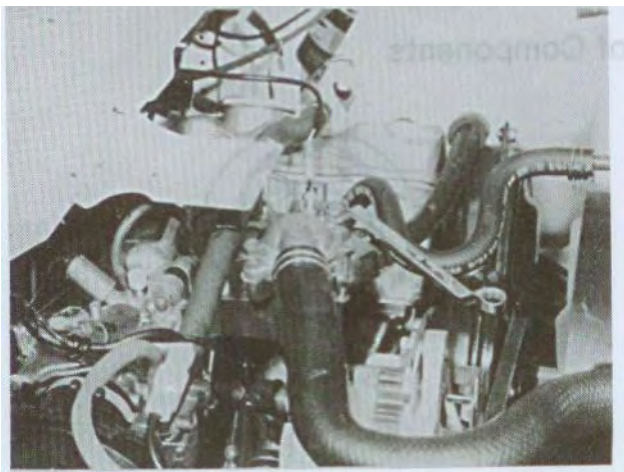

FIG.6-12 (see fig.7-13 of service manual for HFJ6351B)

- (1) Drain cooling system.
- (2) Remove gearlever and cable from transmission and control shaft referring to correlative section.
- (3) Remove central box.
- (4) Remove thermostat cap from intake manifold.
- (5) Remove thermostat. (FIG.6-13)

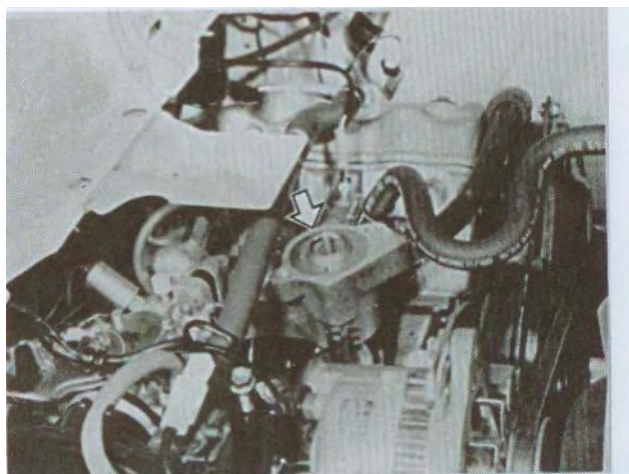

FIG.6-13 (see fig.7-14 of service manual for HFJ6351B)

● Water Pump Removal

- (1) Drain cooling system.
- (2) Remove cooling fan and shroud.
- (3) Loosen water pump belt tensioner and remove water pump pulley and belt.
- (5) Remove crank shaft pulley (FIG.6-14)

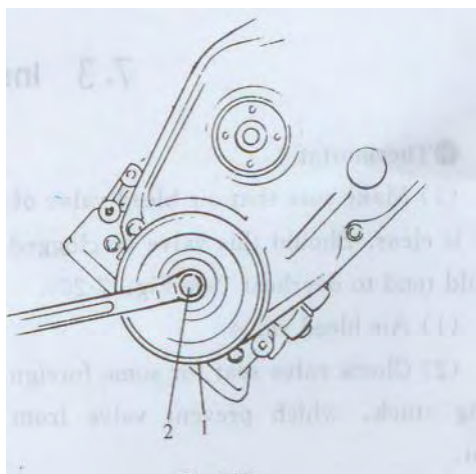

FIG.6-14 (see fig.7-15 of service manual for HFJ6351B)

1 Crank shaft pulley 2 Crank shaft pulley bolt

(6) Remove timing belt outside cover (FIG.6-15)

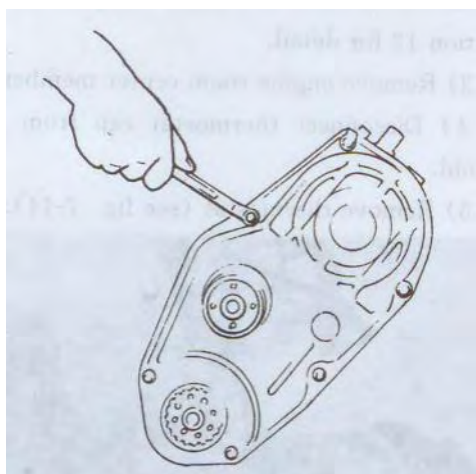

FIG.6-15 (see fig.7-16 of service manual for HFJ6351B)

(7) Loosen tensioner screw (FIG.6-16)

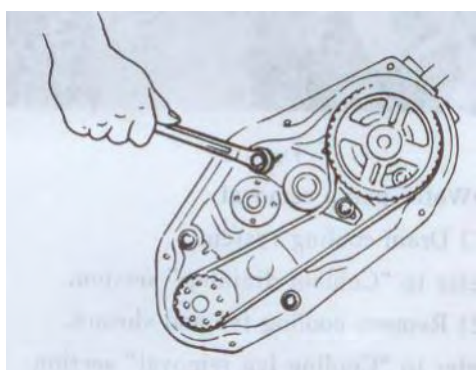

FIG.6-16 (see fig.7-17 of service manual for HFJ6351B)

(7) Remove belt tensioner.

(8) Remove camshaft timing belt pulley using special tool "A" ( FIG.6-17)

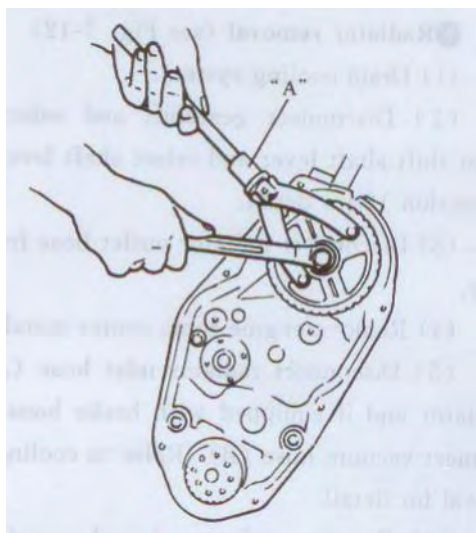

FIG.6-17 (see fig.7-18 of service manual for HFJ6351B)

- (9) Remove crankshaft timing pulley.
- (10) Remove timing belt inner cover.
- (11) Remove water pump (FIG.6-18)

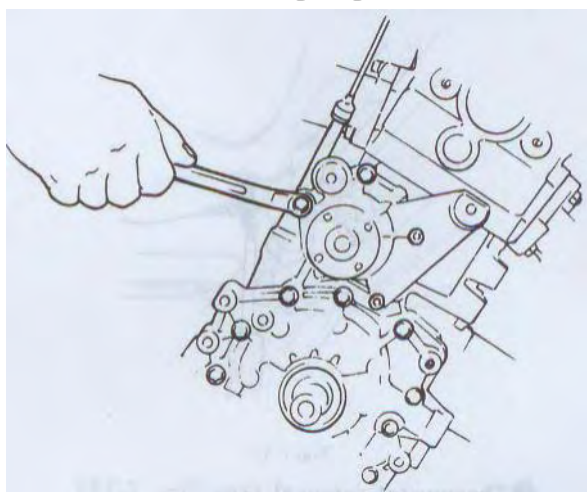

FIG.6-18 (see fig.7-19 of service manual for HFJ6351B)

### 6.3 COMPONENTS INSPECTION

#### ●Thermostat

- (1) Make sure that the air bleed valve of the thermostat is clear. Should this valve be clogged, the engine would tend to overheat. (FIG.6-19)

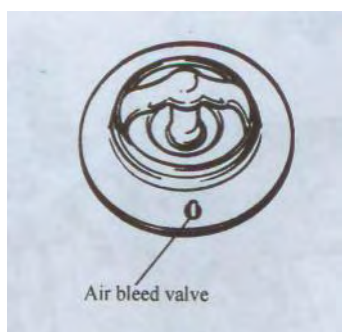

FIG.6-19 (see fig.7-20 of service manual for HFJ6351B)

Draining valve:

(2) Check the valve seat for some foreign matters being stuck which prevents the valve from seating tight.

(3) Check the thermostatic movement of the wax pellet as follows: (FIG.6-20)。

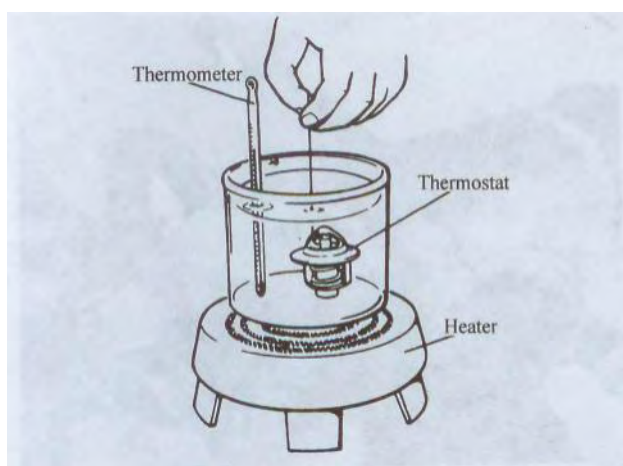

FIG.6-20 (see fig.7-21 of service manual for HFJ6351B)

Thermometer:    Thermostat:    Heater:

- ① Immerse the thermostat in water, and heat water gradually.
- ② Check that valve starts to open at specification temp.
- ③ If the valve starts to open at a temperature substantially below or above, the thermostat unit should be replaced by a new one. Such a unit, if re-sued, will bring about overcooling or overheating tendency.

● Radiator

If there being serious rust or furring in inside of radiator, clean it with radiator scour. The furring and rust will produce sometime later through using the commended coolant. So clean the radiator periodic.

Check radiator core for bent or staving, straighten the bent fin. Clean the core for furring and dirty if necessary.

Serious rust or furring inside radiator will affect cooling effect. Distortional or bent radiator vane will baffle air to affect effect ion.

The interval time of radiator cleaning    two years (Recommended)

--	--

- Water Temperature Sensor.  
Refer to “motor electric” in section 18.
- Water pump

**CAUTION**  
Do not disassemble the water pump.  
If any repair is required on the pump, replace it as

Rotate the water pump by hand to check for smooth operation. If the pump does not rotate smoothly or makes an abnormal noise, replace it. (FIG.6-21)。

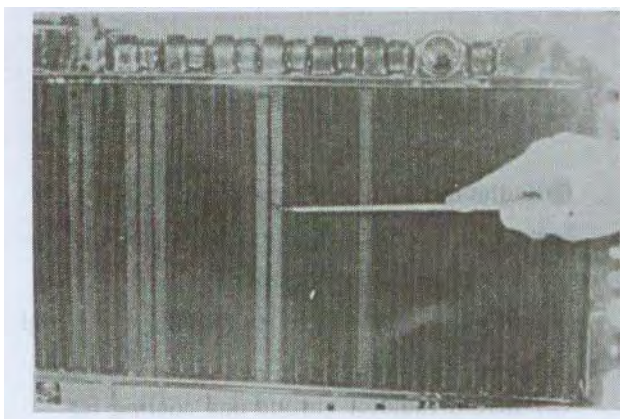

FIG.6-21 (see fig.7-22 of service manual for HFJ6351B)

- Electric Fan  
TROUBLESHOOTING (TABLE 6-2):

TABLE 6-2

Phenomena of Trouble	Potential Cause	Correction
Out of action	1. Open of correlation circuitry	connect
	2. Blown fuse	replace
	3. disconnect of	replace
	4. The trouble of water Temperature Sensor.	Check, repair or replace
	5. The trouble of fan generator	Check, repair or replace
No stopping of electric fan	1. always opening of fan relay	Replace
	2. The trouble of water Temperature Sensor.	Check and Replace

## 6.4 INSTALLATION

### ●Water Pump

- 1) Install new water pump gasket on cylinder.
- 2) Install water pump on cylinder.

Tightening torque of water pump mount bolt and nut N • m 0.9~1.2    kgf • m	9~12
--	------

- 3) Install timing belt inside cover.
- 4) Install crank shaft timing belt guide plate and timing pulley.
- 5) install camshaft timing pulley.

Tightening torque of camshaft timing pulley bolt 5.0~6.0 kgf • m	50~60 N • m
---	-------------

- 6) Remove cylinder head cover and loosen valve adjusting screw of intake and exhaust rock arm
- 7) Install belt tensioner, tension spring, timing belt and outside cover.

#### CAUTION

Be care when installing belt tensioner and timing belt. Refer to correlative section.

Tighten bolts and nuts to specified torque.

- 8) Install crank shaft pulley, water pump pulley, water pump belt.
- 9) Adjust the clearance between intake valve and exhaust valve. (Refer to engine section)
- 10) Adjust water pump belt tension.
- 11) Connect cathode wire of battery.

12) Refill cooling system.

● Thermostats

- (1) Install thermostat to intake manifold ( FIG.6-22)。



FIG.6-22 (see fig.7-24 of service manual for HFJ6351B)

- (2) Install gasket and thermostat cap to intake manifold.

- (3) Refill cooling system.

● The engine with the cooling fan and water pump belt ( FIG.6-23)。

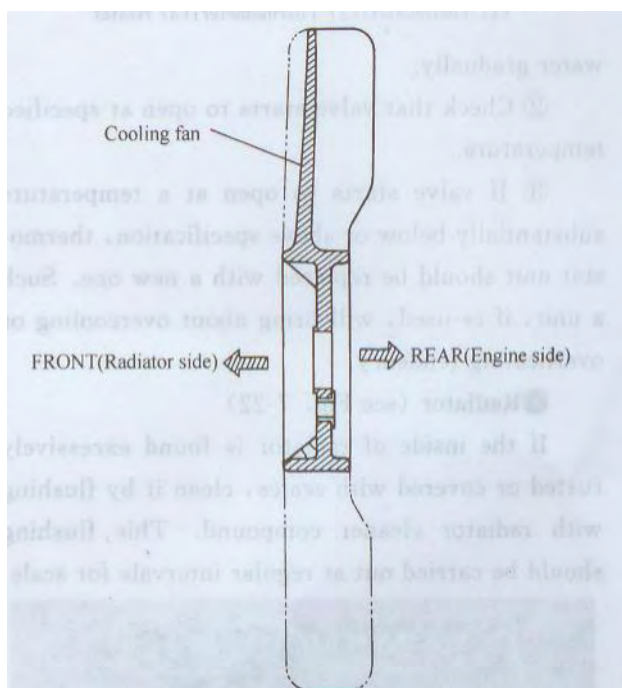

FIG.6-23 (see fig.7-25 of service manual for HFJ6351B)

Cooling fan: Front (side of radiators): rear (side of enging):

The installtion is the reverse of removal procedures and adjust the tension of water pump as regulation.

● Radiators

It is the reverse of removal procedures, pat attention to the followings

- 1) Install tighten bolt and nut rightly;

- 2) Install wind fan and cooling fan.
- 3) Tighten bolt of wind fan and cooling fan.
- 4) Fix inlet and outlet hoses with clip.
- 5) Adjust tension of water pump belt.
- 6) Fill cooling system with a proper coolant.

● Electric fan

It is the reverse of removal procedures.

## 6.5 SERVICE

● Water Pump Belt

- (1) Check belt for crack, deformation, wear and cleanness, the belt is in proper tension when a thumb pressure(10kg) applied to the middle point between water pump pulley and crankshaft pulley deflects it 10~15mm. (FIG.6-24)。

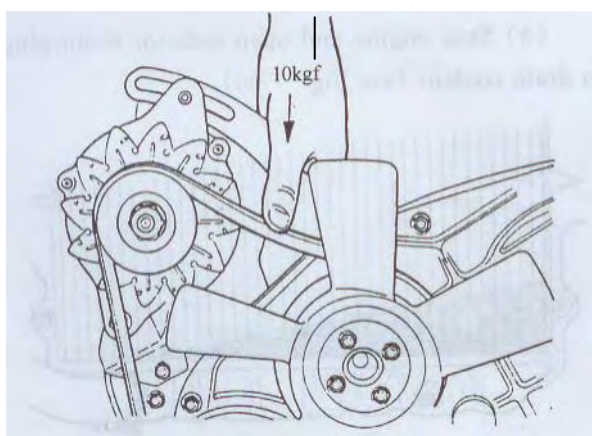

FIG.6-24 (see fig.7-28 of service manual for HFJ6351B)

- (2) If the tension being out of specification, displace the generator to slacken and adjust the belt. (FIG.6-25)。

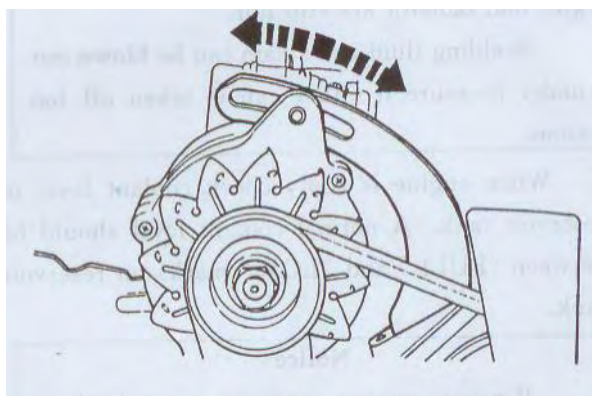

FIG.6-25 (see fig.7-29 of service manual for HFJ6351B)

- (3) Tighten generator adjust bolt and pivot bolt.
- (4) When replacing belt, refer to above removal and installation of belt.

**CAUTION**

All the adjust above should be carried with the engine stopped.

## ●Coolants

The freezing temperature of this coolants is  $-40^{\circ}\text{C}$ , PH value is 7.0~8.5 and other standards conform to glycol coolants according with SH0521. If no coolants, don't use tap water, river water, well water and so on. Permit using distilled water or disposed soft water. But if using in winter, the car must be heat preservation in the storeroom, or draining coolants after stopping in case to freeze the engine or radiator.

### warning

Alcohol or methanol base coolants or plain water alone should not be used in cooling system at any time, which can cause coolants freezed, anti-freeze and anti-corrosion damage, as damage engine and cooling system.

COOLANT CAPACITY	
engine、radiator、heater	3.4L(electric fan:4.4L)
Reservoir tank	0.6L
Total	4L(electric fan:5.0L)

## ●Coolant level

To check level, remove seat and look at “see through” water reservoir tank. It is not necessary to remove radiator cap to check coolant level.

### WARNING:

To help avoid danger of being burned, do not remove reservoir tank cap while coolant is “boiling”, and do not remove radiator cap while engine and radiator are still hot. scalding fluid and steam can be blown out under pressure

When engine is cool, check coolant level in reservoir tank. Abnormal coolant level should be between “FULL” and “LOW” marks on reservoir tank.

## ●Cooling System Service

The cooling system should be serviced as follows:

- 1) Check the cooling system for leaks or damage.
- 2) Wash radiator cap and filler neck with clean water by removing the radiator cap when engine is cold.
- 3) Using a pressure tester, check the system and radiator cap for proper pressure holding capacity 1.1Kg/cm<sup>2</sup>. if replacement of cap is required, use the proper cap specified for this vehicle.
- 4) Tighten hose clamps and inspect all hoses, replace hoses whenever cracked swollen or otherwise deteriorated.
- 5) Clean frontal area of radiator core.

●Cooling System Flush and Filling

1)Remove radiator cap when engine is cool .

**WARNING:**

To help avoid danger of being burned, do not remove reservoir tank cap while coolant is “boiling” ,and do not remove radiator cap while engine and radiator are still hot. scalding fluid and steam can be blown out under pressure if either cap is taken off too soon.

2)With radiator cap removed, run engine until upper radiator hose is hot (this shows that thermostat is open and coolant is flowing through system).

3)Stop engine and open radiator drain plug to drain coolant.

4)Close drain plug. Add water until system is filled and run engine until upper radiator hose is hot again.

5)Repeat 3) and 4) several times until drained liquid is nearly colorless.

6)Drain system and then close radiator drain plug tightly.

7)Disconnect hose from water reservoir tank. Remove tank and pour out and fluid. Scrub and clean inside of tank with soap and water. Flush it well with clean water and drain. Reinstall tank and hose.

8)Add proper mixture coolant and water to radiator and tank. Fill radiator to the base of radiator filler neck and reservoir tank to “FULL” level mark. Reinstall reservoir tank cap.

9)Run engine, with radiator cap removed, until radiator upper hose is hot.

10)With engine idling, add coolant to radiator until level reaches the bottom of filler neck. Install radiator cap, making sure that its ear lines up with reservoir tank hose.

**NOTICE**

1. When replacing coolants, the vehicle must stop on level rode.
2. Coolants must conform to standards and regulation, don't mix with different brands and filling coolants can't be over the limit “FULL” .

## 7 TRANSMISSIONS AND GEAR SHIFT CONTROL

### 7.1 Transmission

- general description

This transmission is synchronization transmission, which have four forward gears and one reverse gear by synchronizer and tow shaft(input shaft and Counter shaft).

The gears of tow shaft(input shaft and Counter shaft) always have been tothing. Low speed gear mounting counter shaft always has been tothing with driven gear of low gear or driven gear of second shaft. High speed synchronizer always has been tothing with driven gear of third gear or driven gear of high speed gear. Reverse gear is impactive gear, which has been tothing by low speed synchronizer bush of Counter shaft and reverse gear of input shaft.

The upper box and the lower box compose the transmission, which is section structure.

Other content refers to service manual for HFJ6351B.

## 8 ELECTRIC CONTROLS

### 1. Combination meter

There are two kind of combination meters on ZHONGYI vehicles with EMS engine. Inspect and service various combination meters (refer to fig.8-1a and fig.8-1b).

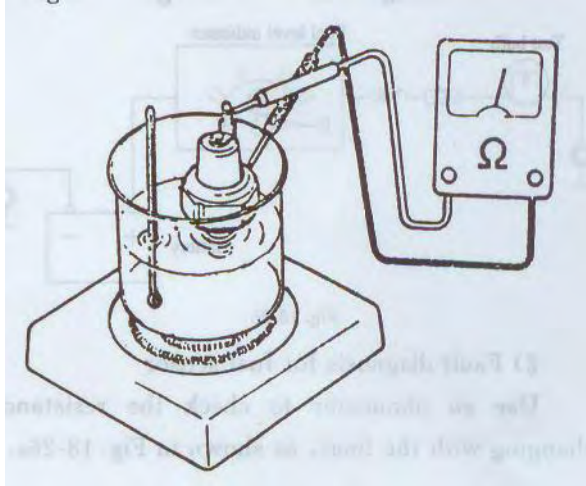

Fig.8-1a) Applied to HFJ6350C, HFJ6351C and HFJ1011 series

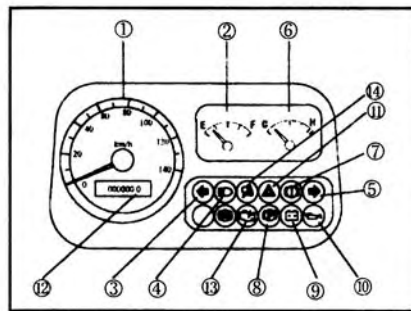

Fig.8-1b) Applied to HFJ6371, HFJ6376 series

- 1-Speedometer; 2-Fuel gauge; 3-Left turn-signal indication lamps; 4- High-beam indication lamp; 5- Right turn-signal indication lamps; 6- Coolant temperature gauge; 7-Brake fluid level warning lamp; 8-Parking brake warning lamp; 9- Charge warning lamp; 10- Oil pressure warning lamp; 11- Hazard warning indication lamps ; 12- Odometer; 13- Check engine indication lamp; 14- Supplemental restraint system(SRS) warning lamp

### 2. Heater wiring diagram

Heater wiring diagram is shown in fig.8-2. Turn the blower speed selection dial to operation position, and turn the water valve control dial to red range, and then air flows from heater are warm. The warm air flows may be used to heat or defrost according to the need. Turn the blower speed dial to the right as you want to add air flows.

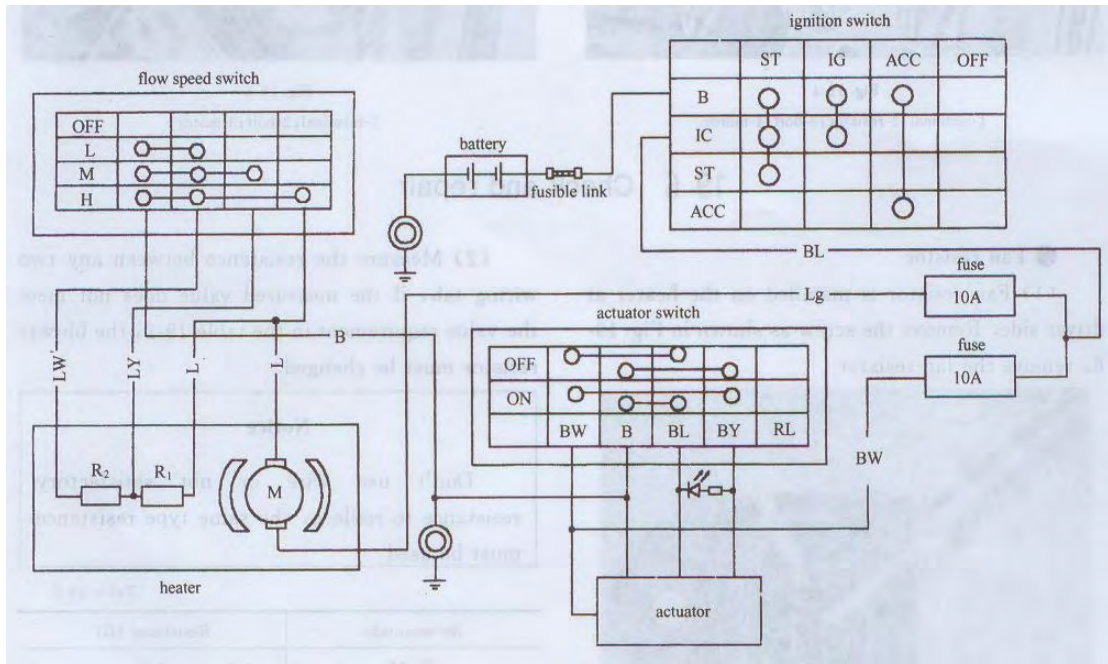

Fig.8-2

When outside air introduction is needed, turn the water valve control dial to the right, and press the actuator switch, and then the damper of air intake box operates, and outside fresh air is introduced into the passenger compartment and exchange with air inside the passenger compartment.

3. Vehicle wiring diagram(shown in fig.8-3a, fig.8-3b, fig.8-3c, fig.8-3d)

**Please see 8-3a)**

Applied to the vehicle with EMS (UAES M1.5.4) engine.

Fig.8-3a)

**Please see 8-3b)**

Applied to the vehicle with EMS (UAES M7.9.7) engine.

Fig.8-3b)

**Please see 8-3c)**

Applied to the vehicle with EMS (DELPHI MT20U) engine.

Fig.8-3c)

**Please see 8-3d)**

Applied to the vehicle with EMS (DELPHI ITMS-6F) engine.

Fig.8-3d)

## CONTENT

### 1 General

#### 1.1 Performance data

### 2 Inspection data and maintenance period

#### 2.1 Torque

#### 2.2 Inspection data

#### 2.3 Maintenance schedule

### 3 Trouble shooting

#### 3.1 Engine

### 4 Engine

#### 4.1 General

#### 4.2 Principle and construction of EMS

#### 4.3 Engine's inspection

#### 4.4 Engine removal

#### 4.5 Disassembly of engines

#### 4.6 Service on engine

#### 4.7 Engine reassembly

#### 4.8 Engine inspection and adjustment

#### 4.9 Engine lubrication

#### 4.10 Maintenance of PCV valve of crankshaft case

#### 4.11 Reassembly of engine

### 5 Air cleaner, fuel pump and fuel filter

#### 5.1 Electric fuel pump, fuel filter and lines

#### 5.2 Emission control system

### 6 Engine cooling

#### 6.1 General description

#### 6.2 Removal

#### 6.3 Components inspection

#### 6.4 Installation

#### 6.5 Service

### 7 Transmissions and gear shift control

#### 7.1 Transmission

### 8 Electric controls

## Description

This service manual is for zhongyi series minivan with EMS engine, all information in it are based on the “ service manual for Songhuajiang Zhongyi minivan HFJ6351B” or “ service manual for Songhuajiang Zhongyi minivan HFJ6350B”, please refer to them.